

Online Marriage and Family Therapy Student Handbook

College of Health and Human Services

ACU Online

Fall 1, 2024

Version 25

Welcome!

Welcome to Online Marriage and Family Therapy at Abilene Christian University. You are part of a group of people selected through careful consideration, and we are glad you have chosen to complete your MFT education with us. During the program, you will be challenged in a variety of ways -- academically, emotionally, mentally, and spiritually. You will learn new ways of viewing relationships and new ideas about how to create change within relationship patterns, and you will grow as a person and in your own relationships.

Your academic and clinical experiences will be significant. Academically, your journey will be guided by official policy as determined by the University. Clinically, your journey will be guided by MFT program policies found in this Handbook.

The Online Marriage and Family Therapy Student Handbook (Handbook) is designed to be an aide to you during the program. It will provide much of the information necessary to complete your journey successfully. It does not, however, supersede any official university policies. It is your responsibility to be familiar with the ACU Student Catalog and Handbook.

This Handbook may be updated as you progress through the program, and you will be notified in writing if changes are made. You are responsible for being familiar with the most current version of this Handbook. When situations arise that are not addressed in this manual, please consult with the Program Director. This Handbook serves as a contract between the Online Marriage and Family Therapy program and you, the student. Please read this Handbook carefully and keep it accessible for quick reference. You should provide a copy of this Handbook to your MFT local program clinical supervisor and to your site supervisor if your MFT local program clinical supervisor is off-site; there are sections that specifically apply to their work with you.

I hope your professional and personal journey to become a marriage and family therapist is rewarding and challenging!

-Dr. Salkil

Table of Contents

Welcome!	2
Table of Contents	3
Mission Statements and Accreditation	6
Relational/Systemic Philosophy	7
Program Goals and Student Learning Outcomes	8
Respect for Diversity	10
Core Faculty Profiles	12
PART I: GENERAL PROGRAM REQUIREMENTS	15
Student Evaluation Process	18
Professional Identity	19
Writing Style and Professionalism	19
Scholarly Journals	20
Capstone Project	21
Theory of Change Paper	21
Clinical Presentation	22
Capstone Preparation Timeline	24
Graduating Student Survey	25
Student Advisory Council	27
PART II: CLINICAL INTERNSHIP REQUIREMENTS	28
Process of Clinical Internship	34
Supervision Definitions	34
Individual Supervision	34
Group Supervision	34
Tracking Observable/Raw Data	35
Client Contact Definitions	36
Holidays and Week Zero	37
Guidelines for Choosing a Clinical Placement	38
Guidelines for Terminating a Clinical Placement Agreement	39
Guidelines for Selecting a MFT Local Program Clinical Supervisor	39
Guidelines for Terminating a MFT Local Program Clinical Supervisor Agreement	40
Supervisor Distinctions	40
PART III: INFORMATION FOR MFT LOCAL PROGRAM CLINICAL SUPERVISORS and SITE SUPERVISORS	45
Internship Sequence	45
Roles of the ACU Faculty/Program Clinical Supervisor	45

Roles and Responsibilities of the MFT Local Program Clinical Supervisor	45
Roles and Responsibilities of the Site Supervisor	48
Supervisor Distinctions	48
Evaluation of the Student Intern	49
Failure to Meet Standards	50
Internship Grievance Policy	51
PART IV: PROGRAM EVALUATION PROCESS	52
PART V: LICENSURE	53
AMFTRB	53
Licensing Boards	53
State Statutes/Laws and Rules	54
Appendices	55
Appendix A	55
Degree Plans	55
Appendix B	63
Student Learning Outcomes Assessment Schedule	63
Appendix C	68
Basic Skills Evaluation Device	68
Appendix D	77
Capstone Project Evaluation Rubrics	77
Appendix E	79
Internship Checklist Of Prerequisites	79
Appendix F	80
MFT Local Program Clinical Supervisor Application	80
Appendix G	81
Internship Site Application	81
Appendix H	82
Tracking Client Contact And Supervision	82
Appendix I	83
AAMFT Code Of Ethics	83
Appendix J	84
ACU Ethics Protocol	84
Appendix K	86
FAQs	86
Appendix L	89
MFT Local Program Clinical Supervisor Evaluation	89
Appendix M	90

Evaluation Of Clinical Internship	90
Appendix N	91
Internship Search Process	91
Appendix O	93
Program Costs	93
Appendix P	94
Student and Graduate Achievement Goals & Outcomes Assessment Report (OAR)	94

Mission Statements and Accreditation

The mission of Abilene Christian University is to educate students for Christian service and leadership throughout the world. This mission is achieved through:

- Exemplary teaching, offered by a faculty of Christian scholars, that inspires a commitment to learning;
- Significant research, grounded in the university's disciplines of study, that informs issues of importance to the academy, church, and society; and
- Meaningful service to society, the academic disciplines, the university, and the church, expressed in various ways, by all segments of the Abilene Christian University community.

The mission of MFT Online is to graduate clinically competent, ethical, and professionally engaged marriage and family therapists. This mission is accomplished through equipping MFT students to:

- Provide effective intervention to diverse couples, families, and individuals dealing with a range of relational and mental health issues from a systemic perspective;
- Critically reflect on MFT research and utilize research findings to inform evidence-based practice;
- Engage in ethical decision-making processes; and
- Cultivate a sense of vocation informed by Christian principles.

The Program is accredited by the Commission on Accreditation for Marriage and Family Therapy Education (COAMFTE), (703) 253-0448, coa@aamft.org.

Relational/Systemic Philosophy

Students can expect their coursework and supervision will train them in a relational/systemic philosophy. As defined by the Commission on Accreditation for Marriage and Family Therapy Education (COAMFTE), this “perspective focuses on relationships, including patterns of interaction between individuals that organizes relationship dynamics, with an emphasis on what is happening rather than why it is happening” (COAMFTE, 2021, p. 36).

In clinical work, students are encouraged to enact this philosophy by involving as many members of the family or social system as possible in therapy. For example, students working with children or adolescents should include all parents or legal caregivers in session. If that is not possible, students should be prepared to discuss in group and/or individual supervision the theoretical rationale for excluding a member of the system.

Program Goals and Student Learning Outcomes

Program Goals	Student Learning Outcomes
1. Demonstrate competency in the practice of systemic therapy with diverse couples, families, and individuals.	1.1 Understand foundational systems concepts, theories, and techniques of marital, couple, and family therapy.
	1.2 Recognize contextual and systemic dynamics with a commitment to diversity and inclusion.
	1.3 Understand principles of human development, human sexuality, gender development, psychopathology, psychopharmacology, couples processes, & family development processes.
	1.4 Distinguish differences between content and process issues.
2. Demonstrate competency in assessing, hypothesizing and diagnosing.	2.1 Develop systemic hypotheses and assess family history and dynamics from a systemic perspective.
	2.2 Recognize contraindications for couples and family therapy.
	2.3 Understand behavioral health disorders including the epidemiology, etiology, phenomenology, effective treatments, course, & prognosis.
	2.4 Systematically integrate client reports, observations of client behaviors, client relationship patterns, reports from other professionals, results from testing procedures, and interactions with client to guide the assessment process.
3. Demonstrate competency in designing and conducting systemic treatment.	3.1 Know which models, modalities, and/or techniques are most effective for presenting problems and apply them to diverse couples and families.
	3.3 Integrate client feedback, assessment, contextual information, and diagnosis with treatment goals and plan.
4. Demonstrate competency in evaluating ongoing process and terminating treatment.	4.2 Develop measurable outcomes, treatment goals, treatment plans, and after-care plans with an eye toward termination.

5. Demonstrate competency in managing crisis situations.	5.1 Understand how crisis and trauma impact the family system.
	5.2 Manage risks, crises, and emergencies using recognized standards of practice.
6. Demonstrate competency in maintaining ethical, legal, and professional standards.	6.1 Know state, federal, & provincial laws & regulations as well as professional ethics and standards for clinical practice and research.
	6.2 Understand the process of making an ethical decision and recognize dilemmas in which ethics, laws, and professional liability apply.
	6.3 Monitor attitudes, personal well-being, personal issues, and personal problems and ascertain their influence on ethical practice.
	6.4 Articulate a personal spiritual/religious perspective on the discipline of marriage and family therapy.
7. Demonstrate competency in understanding, critically evaluating, and clinically applying relational/systemic research.	7.1 Understand the relationship between research and evaluative practices.

Respect for Diversity

The Online Marriage and Family Therapy (MFT) program is committed to creating a learning context that is characterized by the inclusion of multiple groups in the student body and faculty. Further, the faculty and program leadership view matters of diversity as integral to the foundational curriculum and foundational practice component. The program defines diversity as acknowledgment and acceptance of individual factors including but not limited to: race, age, gender, ethnicity, gender identity, sexual orientation, housing status, immigration status, socioeconomic status, disability, health status, and religious and spiritual practices. The program aspires to include representation of these contextual factors in the student body and faculty.

The university's mission is to “educate students for Christian service and leadership throughout the world.” The mission of MFT Online is to graduate clinically competent, ethical, and professionally engaged marriage and family therapists. More specifically, students and graduates will provide effective intervention to diverse couples, families, and individuals and cultivate a sense of vocation informed by Christian principles.

Our calling as people of faith is to be Christ's body for mission and service in the world. As faculty and students in ACU's online marriage and family therapy program, we aspire to serve our clients faithfully by learning the science of marriage and family therapy and applying it skillfully and ethically. The course of study in the program requires a commitment to the Christian principles of honesty, integrity, and hospitality. It is with the principle of hospitality in mind that we aspire to celebrate the gift of diversity by employing faculty and recruiting students with diverse ethnicities, experiences, interests, abilities, and training. Because the program aspires to graduate clinically competent, ethical, and professionally engaged marriage and family therapists, the curriculum and practice component seeks to be enriched by diverse ideas, thoughts and perspectives.

Faculty and staff within ACU, and within the Online MFT program, understand that creating a learning environment that accepts and respects diversity requires intentional practice. Such a learning environment must extend beyond the classroom. A total learning environment in which respect for, and acceptance of, diversity must be cultivated explicitly and implicitly throughout the program. Explicit content on diversity is integrated throughout the curriculum and taught by instructors who model respect for, and appreciation of, diversity. This culminates in a required emphasis in the final Capstone presentation required of each student. Implicitly, the Online MFT program models respect for, and appreciation of, diversity in its policies, procedures, recruiting, daily practices, and attitudes. As a professional MFT training program in the landscape of

Christian higher education, appreciating and respecting all humans, regardless of differences, is of utmost importance.

Core Faculty Profiles

Dr. Sara Salkil

Sara Blakeslee Salkil, Ph.D., LMFT (TX), IMFT (OH) is the founding program director of the Online Marriage and Family Therapy program at ACU Dallas. She previously spent five years at the residential campus of ACU where she was an assistant professor and clinic director in the MFT program. She is independently licensed as a Marriage and Family Therapist in Ohio and Texas and is an AAMFT-Approved Supervisor. Sara grew up in Oklahoma and earned her bachelor's degree in Marketing from Oklahoma State University. She received her master's degree in marriage and family therapy from ACU and her doctorate in MFT from Texas Tech University. In addition to her academic work, she is a commissioner with the Commission on Accreditation for Marriage and Family Therapy Education. She also practices part-time and specializes in working with couples. She is married, has a stepson in college, and lives in Cincinnati, Ohio.

Dr. Jackie Halstead

Jackie Halstead, Ph.D., LMFT, MDiv, has been with ACU Dallas since 2016 serving now as the Associate Director for the online Marriage and Family Therapy program. She was on the residential campus from 1998 to 2010 where she served as program director and department chair for the MFT program. On the side, she runs Selah Center for Spiritual Formation. This non-profit offers a certificate program in Spiritual Direction and online courses in the Christian Spiritual Disciplines and other spiritual topics. Dr. Halstead has been a licensed Marriage and Family Therapist for the past thirty-six years—specializing in ministers and their families--and a Spiritual Director for twenty years. She speaks frequently on the topics of holistic well-being, mental health, relationships, contemplative prayer, and spiritual formation at the national and international levels. Jackie has been married to Randy for 41 years and they live in Nashville, Tennessee. They have two grown daughters, Erin (married to Stephen) and Ashley and, most importantly, a grand-daughter, Jocelyn.

Dr. James Morris

James Morris received his PhD in family therapy from Texas Tech University in 1987. He has worked in community based non profit family therapy, home-based family therapy, rural family therapy, and academia. He has served as the President of the American Association for Marriage and Family Therapy (AAMFT), as well as President of the New Mexico AMFT, and the Texas AMFT. He has published a number of articles in family therapy journals, as well as book chapters and book reviews.

Dr. Drew Jamieson

Drew Jamieson has been with ACU Dallas since 2017. He began his clinical experience as a Marriage and Family Therapist in 2005 and has worked in various settings, including an oncology center, residential addiction treatment, and private practice. He currently maintains a part-time private practice and provides supervision for postgraduate clinicians as an AAMFT Approved Supervisor. He is an LMFT in Alabama and North Carolina and a past board member for ALAMFT. He has an MDiv in Pastoral Care and Counseling, a ThM in Counseling, and his PhD in MFT. He currently lives in Florence, Alabama with his wife and son, with another son and three daughters living all over.

Dr. Maxine Notice

Maxine Notice Ph.D., LMFT, LMHC, NCC received a bachelor's degree in Psychology from the University of Maine at Presque Isle, a master's degree in Mental Health Counseling from CUNY City College, and a Ph.D. in Applied Psychology with a specialization in Marriage and Family Therapy from Antioch University New England. She is passionate about systemic research and education and has previously held positions as a Post-Doctoral Research Fellow at the University of Nebraska Medical Center, and as an Assistant Professor at the University of Central Missouri. Dr. Maxine currently owns a private practice where she focuses on providing pre-marital counseling, and systemic supervision. Though a New York City native, she currently resides in Kansas City with her husband.

Dr. Tim Parker

Dr. Tim Parker, PhD, LMFT-S (TX), LMFT (CO) completed his Ph.D. in Marriage and Family Therapy at Texas Tech University where his dissertation focused on coping and resilience in couples who have a child with Down Syndrome. He also holds a Master's degree in Marriage and Family Therapy from Abilene Christian University. Dr. Parker completed his Bachelor's degree at Rochester University in Michigan. He has a private practice where he works with couples, families, and individuals experiencing a wide range of life stressors. He has been a full-time and part time faculty member for both in-person and online Marriage and Family Therapy programs. His research interests range from suicide prevention with men in intimate relationships to systems theory and its relationship with the ecclesiastical community. When not teaching or providing therapy, Dr. Parker enjoys the finer things in life such as spending time with family friends, eating smoked meats, and cheering on his beloved Detroit Lions.

Dr. Stephanie Steele

Dr. Stephanie Steele is a LMFT and specializes clinically in couple's therapy. She earned a bachelor's degree in Psychology from Kansas State University, a master's degree in Marriage and Family Therapy from Valdosta State University, and a Ph.D. in Psychology with a specialization in Marriage and Family Therapy from Northcentral University. She has been teaching with Abilene Christian University since 2019 and has a passion for educating future clinicians and helping them navigate their marriage and family therapy careers. Growing up in the Seattle area, she now lives and thrives in the California sunshine with her husband and four daughters.

Dr. Aaron Maleare

Aaron Maleare, Ph.D., LMFT-S (TX), LMFT (NC) completed his Ph.D in Counseling and Psychological Studies at Regent University where he was the recipient of the competitive Trailblazer Scholarship which provided full-tuition for this degree. His dissertation focused on the critical intersection of mental health and communities of faith in order to find ways of offering competent mental health care where people are seeking support. Dr. Maleare also holds a Master's degree in Marriage and Family Therapy from Abilene Christian University and Master's degree in Theological Studies from Lipscomb University. He has worked in a variety of clinical settings; community non-profit, in-patient psychiatric hospital, high-end "boutique" therapy, and now runs his own private practice - when he's not teaching. He has a passion for teaching and training the next generation of therapists whether that is in a classroom setting or through providing supervision post-graduation. When he's not counseling or teaching, Dr. Maleare enjoys spending time with his family, eating all kinds of food, and traveling.

Dr. Marcus N. Tanner

Marcus Tanner Ph.D., LMFT-S (TX), CMFT-S (NM), has been with ACU Dallas since 2018, serving primarily as an instructor for the Internship in the online Marriage and Family Therapy program. He is the owner and operator of HealingChoice Family Therapy a small group practice focused on providing trauma care and couples therapy. He is a Certified Gottman Therapist and specializes in providing care to couples with relationship betrayal. He is an AAMFT-Approved Supervisor and enjoys training both students and post-graduate MFTs at HealingChoice. He is married, with two adult children, and lives in Lubbock, TX.

PART I: GENERAL PROGRAM REQUIREMENTS

Degree Plan

The degree plan for the online Marriage and Family Therapy program consists of either 45 or 48 credit hours in the Foundational Curriculum and either 9 or 12 credit hours in the student's choice of specialization: General MFT, Treatment of Trauma (TOTR), Child & Adolescent Therapy (CATH), or Therapy with Military Families (THMF).

Prior to beginning Internship, students must complete the first 18 credit hours in the program, earn a minimum cumulative 3.0 GPA in the first 12 hours, and receive a minimum grade of B in MFTO 601 Pre-Internship. Students must also be in good standing.

- MFTO 639 Family Theory
- MFTO 641 Family Therapy I
- MFTO 601 Pre-Internship
- MFTO 643 Professional Ethics and the Law
- MFTO 661 Family Therapy II*
- MFTO 663 Cultural Diversity in Family Therapy*
- MFTO 645 Systemic Assessment & Diagnosis*

*These courses rotate as the fifth, sixth, and seventh courses

The remaining courses for all students include:

- MFTO 602 Internship I
- MFTO 603 Internship II
- MFTO 604 Internship III
- MFTO 605 Internship IV
- MFTO 606 Internship V
- MFTO 607 Internship VI
- MFTO 608 Internship VII*
- MFTO 609 Internship VIII*
- MFTO 610 Couples Therapy
- MFTO 615 Research Methods in Family Therapy
- MFTO 634 Addictive Disorders
- MFTO 651 Sex Therapy
- MFTO 662 Family Life Cycle

*These courses are for students who elect to earn 500 client contact hours.

Students in the general MFT track will complete the following courses:

- MFTO 665 Therapy across the Life Cycle
- MFTO 697 Ecology of Trauma and Crisis for the Therapist
- Elective
- Elective

Students in the Treatment of Trauma track will complete the following courses:

- MFTO 630 Trauma Intervention Models
- MFTO 655 Systemic Trauma and Violence
- MFTO 657 Assessment and Treatment of Family Violence
- MFTO 697 Ecology of Trauma and Crisis for the Therapist

Students in the Child & Adolescent Therapy track will complete the following courses:

- MFTO 622 Systemic Play Therapy
- MFTO 624 Family Therapy with Children and Adolescents
- MFTO 628 Assessment and Treatment of Child and Adolescent Disorders
- MFTO 697 Ecology of Trauma and Crisis for the Therapist

Students in the Therapy with Military Families track will complete the following courses:

- MFTO 657 Assessment and Treatment of Family Violence
- MFTO 682 Dynamics of Military Families
- MFTO 684 Family Therapy with Military Families
- MFTO 697 Ecology of Trauma and Crisis for the Therapist

The degree plan is designed such that students take one course at a time prior to beginning Internship. There may be occasions when the student is able to “double up” on coursework. To be eligible to take two non-Internship courses at the same time, students must meet all of the following criteria:

- Complete a minimum of 18 hours (transfer credits are excluded)
- GPA is an average of 3.0 or higher for all MFTO coursework (other graduate coursework is excluded)
- The courses are already scheduled to run
- The student is not on a student success plan or other programmatic remediation.

Students should contact their Graduate Student Success Advisor for such requests.

See Appendices for the degree plans. Students are advised to remain in regular contact with their Student Success Advisor and Financial Aid Specialist throughout the program, especially if there are any deviations to the degree plan due to change in student status with the university such as an academic break, course withdrawal, retake, or a deferred entrance into the Internship.

Student Evaluation Process

Competence in the discipline of marriage and family therapy cannot be measured only through grades earned in courses. The evaluation of clinical and professional skills is dependent upon students' work in their internships. Rather than gathering data only from local/site supervisors, however, the evaluation will be a recursive process in which students also evaluate themselves by offering responses to their goals. In addition, students will be formally evaluated by their MFT local clinical supervisor on their clinical competence a minimum of three points throughout the program:

- During MFTO 603 Internship II
- During MFTO 605 Internship IV
- During MFTO 607 Internship VI
- During MFTO 609 Internship VIII*
- During MFTO 698, 692, or 693, which are the Internship Continuation courses, if needed

*Those students who elect to earn 500 client contact hours will have an additional clinical evaluation.

The Basic Skills Evaluation Device (Nelson & Johnson, 1999)¹ is utilized for the completion of student evaluations. The BSED is included in the Appendices.

¹ Nelson, T. S., & Johnson, L. N. (1999). The basic skills evaluation device. *Journal of Marital and Family Therapy*, 25, 15-30.

Professional Identity

Being professionally engaged in the field of marriage and family therapy is an important step in developing an identity as a systemic therapist. To facilitate this development, all students will be required to join the American Association for Marriage and Family Therapy and maintain an active membership throughout their time in the program. Dues and enrollment information can be found at aamft.org. One benefit of student membership is receiving malpractice insurance coverage, which is a requirement of the Internship process. Students must join the AAMFT during their MFTO 601 Pre-Internship course and submit proof of enrollment; this is a prerequisite to beginning Internship. The annual membership fee is not included in student tuition or fees.

Writing Style and Professionalism

All formatting and referencing for papers written in the program should follow the current edition of *The Publication Manual of the American Psychological Association*, which is a required text in the program. Papers should be written in Times New Roman 12-point font. All papers should be neat, contain no misspellings, contain no typing errors, and employ proper grammar and syntax. The final paper is expected to be professional in appearance. Papers should include an introduction, a body, and a conclusion.

The mission of the MFT program is to *graduate clinically competent, ethical, and professionally engaged marriage and family therapists*. This mission is accomplished through equipping MFT students to do the following:

- Provide effective intervention to diverse couples, families, and individuals dealing with a range of relational and mental health issues from a systemic perspective;
- Critically reflect on MFT research, and utilize research findings to inform evidence-based practice;
- Engage in ethical decision-making processes; and
- Cultivate a sense of vocation informed by Christian principles.

Learning to provide effective systemic intervention is a skill and program goal. That is, when you graduate, we expect you will be able to apply a systemic approach to working with a family system. However, there is an additional skill to our work as professional therapists that you must learn while in the program. *Communicating precisely and professionally* in your written correspondence is a critical aspect of providing any systemic intervention with families.

During your Internship, you will be expected to write case notes and treatment plans. These documents are considered a part of the client file. These documents contain diagnostic information, protected health information, and a summary of the progress toward goals and interventions used in session. The client file will be viewed by your supervisor and could possibly be viewed by others outside the site, including attorneys, judges, or other mental health providers. In addition, you will identify yourself as a professional in all your written communication, including emails, cover letters, grant applications, resumes, etc. For these reasons, it is imperative that you learn the proper grammar, syntax, and APA style that is reflective of a master's level MFT graduate.

The faculty adhere to the *The Publication Manual of the American Psychological Association* as the guide for professional and scholarly writing. It is imperative that you review the manual and master the nuances of academic writing. There are many resources available to assist with your writing, including the [Online Writing Center](#), Tutor.com, Grammarly, and TurnItIn Draft Coach.

Your faculty may offer some direction but it is your responsibility to master the content of the manual and apply it to your work. If papers contain pervasive APA and/or grammatical errors, the faculty may return the paper without grading it. In these cases, you will likely be directed to the Online Writing Center for assistance and will lose points for late work.

Your writing is a reflection of your work with clients. The faculty invite you to renew your commitment to consulting the *APA Publication Manual* for all of your work in the program.

Scholarly Journals

In order to be immersed in relational/systemic approaches, it is imperative to be conversant with the marriage and family literature. Students should review the [list of acceptable journals](#) found on the Master of Marriage and Family Therapy Online Program [Library Guide](#) and use those journals to complete course assignments.

Capstone Project

The purpose of the capstone project is to assess the student's ability to integrate knowledge of MFT theories, models, and research with clinical practice. There are two portions to the capstone project: 1) a theory of change paper and 2) a clinical presentation. Each portion is described in more detail below. Students must pass both parts of the capstone project in order to graduate from the program.

Theory of Change Paper

Students will write a 15-20 page theory of change paper of professional, journal quality using primary source material that addresses his or her primary theoretical orientation for treating relational systems. For example, students may choose to write about Structural Family Therapy and apply it to a particular family system in their caseload. This paper is an intellectual exercise in which the student presents his/her theory of change with specific references to reputable research and theory. The paper should demonstrate critical thinking as well as the ability to integrate theory of change of General Systems Theory along with that of the therapeutic modality chosen by the student. Rather than consisting of disjointed pieces, the sections of this paper should inform one another. For example, one's philosophical/theological/spiritual considerations should make sense in light of the theory one chooses and vice versa. It is imperative that students consult with the instructor of their internship course for direction. The paper must adhere to APA standards. All students must provide proof that the final copy of their paper has been submitted to the Online Writing Center and that feedback has been incorporated. Papers that are submitted without having been reviewed by the Online Writing Center will be returned, ungraded. This will count as the first submission.

Students may use first person in the writing of this paper. Students should use 15-20 references. The paper should include the following sections/topics:

- Introduction
- Literature review on systemic change in therapy
 - The literature review provides the foundation for the theory of change presented by the student. It will include a focus on General Systems Theory in addition to the assumptions of change underlying the chosen modality.
- Theoretical considerations
 - This section should include a summary and discussion of the underlying assumptions of the model as well as an explanation of dysfunction and change through the same theoretical lens.
- Philosophical/theological/spiritual considerations of change

- This section is a discussion and reflection of the manner in which the student conceptualizes therapeutic change through a philosophical, theological, or spiritual lens. A minimum of two references in addition to sacred texts such as the Bible, the Qur'an, the Talmud, the Vedas, the Book of Mormon, etc. is required.
- Integrated theory of change
 - Based on research, theoretical considerations, and philosophy/theology/spirituality, what is the student's theory of change? How does the student integrate these topics to explain their personal theory of change? For example, a student who selects Structural Family Therapy will describe how the tenets of that model along with the student's theological view of change form a coherent, integrated approach toward family therapy.
- Application in therapy
 - This section should include a brief description of the system, including contextual and systemic dynamics
 - The section should contain an explanation utilizing the student's theory of change with a relational client system in the following phases of therapy:
 - Assessment/engagement
 - Interventions
 - Termination
 - Identify and discuss ethical considerations and legal issues. Students should consider the nuances of the case and describe applicable legal and ethical issues.
- Conclusion

Clinical Presentation

The student must also prepare a 30- to 40-minute clinical presentation during which time he or she will present a case study including video clips from a relational client system that the student has worked with in his/her internship. The student cannot be working as part of a co-therapy relationship with the system selected for the Capstone. The clip selections should be a minimum of 10 minutes but no longer than 20 minutes long and should illustrate the stages of the student's particular model of therapy in a relational system. On rare occasions, there may be a reason to show one clip containing only an individual client from the larger relational system. The decision to show a clip of that nature should be defensible and demonstrate progression through a systemic treatment plan. The presentation should include clips from various stages of therapy, spanning multiple sessions. The presentation should begin with a **brief** description of your integrated theory of change. The majority of the presentation should focus on the case study with the following points being addressed:

- Succinctly provide an overview of general systems theory and cybernetic concepts that inform family therapy

- Briefly describe the client system, including the initial assessment. Include relevant data from the intake/assessment packet.
- Describe a conceptualization/systemic hypothesis of the case. This should be informed by the student's integrated theory of change
- Identify and discuss ethical and legal issues. It is insufficient to say there are no ethical and legal issues. Students should consider the nuances of the case and describe applicable legal or ethical issues.
- Identify and describe issues of diversity. It is insufficient to say there are no issues of diversity because the clients and/or therapist may be from the dominant culture.
- Using the *DSM-5-TR*, state diagnostic impressions for each of the members of the system. Discuss the basis for these diagnoses.
- Discuss all referrals made and any consultations engaged in, including supervision consultations.
- Describe the stages of therapy and the interventions used based on the integrated theory of change.
- Describe the progress of the case over time.
- Assess how the case reflects the theory of change. Evaluate the quality of therapy with the case. Reflect on the personal journey of selecting the theory.

Students should approach the Case Study Presentation with thoughtful preparation. Professional dress is required and students should ensure they are familiar with any technology needed for the presentation (PowerPoint, Zoom, etc.). A reliable internet connection is of critical importance. Students should schedule the presentation to ensure confidentiality when showing observable/raw data. Faculty will end presentations at the 40-minute mark.

The capstone project committee will be composed of two members, where at least one member is a core faculty. Each will be responsible for rating the paper as well as the presentation. The members of the committee will determine an average grade for the presentation based on the rubrics included in the Appendices. An average score of 3 or above for the paper and the presentation is an outright pass. An average grade of 2-2.99 is a pass with reservations and will include an additional writing and/or presentation assignment. Students must score an average score of 3 or above on the additional writing and/or presentation to pass the second attempt. Any score at or below 1.99 is failing. Both portions of the capstone project must be passed outright in order for the student to complete degree requirements.

Students who do not pass the Capstone and must resubmit one or both portions but do not pass by the end of MFTO 607 will be able to proceed into the next course (for those earning 500 hours). The Capstone is a degree requirement and students will not be cleared for graduation

without passing both portions. Students who do not pass one or both portions after three attempts will be required to enroll in MFTO 617 Internship Capstone Continuation.

A student has the right to appeal the decision of the Capstone Project committee through procedures described in the ACU Catalog and Handbook.

Capstone Preparation Timeline

Students should review the milestone assignments below to obtain an overall perspective of how the assignments in Internship courses are aligned to support preparation for the Capstone process. Full details of these assignments can be found in the Internship course syllabi. In order to be sufficiently prepared, students are encouraged to thoroughly and diligently complete the milestone assignments (see the table below). These assignments allow your program clinical faculty to provide feedback that will assist you in meeting the minimum standards of the Capstone Theory of Change Paper and Clinical Presentation. Of particular importance are the Raw Data Assignments. Showing raw data in individual and group supervision allows your supervisors to provide feedback about your clinical work. This is a critical step in preparing for the Capstone.

The faculty of the program have determined the following models are approved for the Capstone presentation and paper. The theory courses are listed so students can identify in which course they will be exposed to the model.

- Gottman - MFTO 610
- Integrative Behavioral Couples Therapy - MFTO 610
- EFT - MFTO 610 and 661
- Bowen - MFTO 641
- Structural - MFTO 641
- Strategic (Jay Haley) - MFTO 641
- Satir - MFTO 641
- MRI - MFTO 641
- SFBT - MFTO 662
- Narrative - MFTO 661
- Collaborative Language - MFTO 661
- Multidimensional - MFTO 628
- Multisystemic - MFTO 628
- Attachment (Diamond) - MFTO 661

Other models that are not specifically taught in the program:

- Symbolic-Experiential (Whitaker)

- Milan
- Object Relations (Framo; Scharff & Scharff)
- Contextual (Boszormenyi-Nagy; Hargrave)

Other models may be considered upon request. Students wishing to utilize another model should reach out to their ACU program clinical supervisor and the program director.

Capstone Milestone Assignments	
Course	Assignment
MFTO 602 Internship I	Raw Data Assignment, week 5
	Theory of change discussion, week 7
MFTO 603 Internship II	Raw Data Assignment, week 3
	Faith integration discussion, week 5
MFTO 604 Internship III	Raw Data Assignment, week 2
	Raw Data Assignment, week 5
	Theory of change discussion, week 7
MFTO 605 Internship IV	Raw Data Assignment, week 1
	Abbreviate Capstone Presentation, week 4
MFTO 606 Internship V	Theory of Change Paper Outline, week 1
	Theory of Change Draft, week 4
	Full-length Mock Capstone Clinical Presentation
MFTO 607 Internship VI	Capstone Theory of Change Paper and Clinical Presentation, week 1

Graduating Student Survey

As students prepare to graduate from the program, they will be given the opportunity to provide comprehensive feedback to the program about their experiences. Students will evaluate the program's role in helping them to achieve Student Learning Outcomes and Program Goals.

Additionally, students will provide feedback about the sufficiency of student and program resources, teaching practices, and faculty needed to achieve the SLOs and Program Goals.

Student Advisory Council

Students will have the opportunity to be elected as members of the Student Advisory Council (SAC) whose purpose is to advise the program leadership of questions or concerns about the program. Nine members will be elected annually and serve for one calendar year. Three members will be elected from courses 1-6, three members will be elected from courses 7-12, and three members will be elected from courses 13-20. (When calculating courses taken, the number of courses will include the Spring 1 term.) The SAC will meet once each term, with dates to be provided at the beginning of the calendar year. Members must attend 4 of the 6 meetings during the year or they will be removed from the SAC. A member of the core faculty will serve as liaison to the SAC.

Nomination and Election Process

- Nominations will open at the beginning of the Spring 1 term and remain open for one week.
- Students may nominate themselves or someone else.
- Students who are nominated may accept or decline to run.
- After nominations, faculty and advisors will vet the students to ensure they are in good standing in the program. Their academic progress will be reviewed as well as their history of communication with faculty and staff. Any students who are deemed ineligible will be notified by the program director.
- Students who are on academic probation are not eligible to run.
- The ballot will be sent out to all active students by the third week of the term and will remain open for one week.
- The results of the election will be announced by the program director by the fifth week of the term.

PART II: CLINICAL INTERNSHIP REQUIREMENTS

Introduction and Purpose

Clinical training is a core aspect of graduate education in Marriage and Family Therapy. Clinical training engages the student in applied learning experiences from a relational/systemic philosophy under close supervision by licensed marriage and family therapists. To meet the clinical requirements of the program, students will have two paths to earn client contact and satisfy degree requirements. On one path, students must complete a total of 500 hours of direct client contact with a minimum of 200 hours of relational therapy hours (provided to a couple or family). On the other path, students must complete 300 hours of direct client contact with a minimum of 100 hours of relational therapy. Students are not allowed to be enrolled in Internship once clinical requirements, required Internship courses, and the Capstone project have been successfully completed.

All students must receive a minimum of 100 hours of supervision from a program clinical supervisor on a regular and consistent basis while seeing clients. In each path, a minimum of 50 hours of supervision must be based upon observable/raw data (video content), which is in keeping with the best practices for clinical training in the MFT field. In some cases, students may be required to pay for MFT local clinical supervision if the practicum site or the supervisor is not willing to provide it free of charge.

For students beginning Internship in Spring 1, 2023 or later, the program requires 3 hours of live supervision. Live supervision is a form of supervision where the supervisor guides the therapist as the session is occurring. The supervisor watches the session, usually behind a one-way mirror, and provides feedback in a variety of ways (Montalvo, 1973). Perhaps the most common method of feedback is the mid-session break. Live supervision is an important tool in the training of marriage and family therapists (Berger & Damman, 1982; Liddle & Schwartz, 1983).

Students will have a graded assignment in MFTO 603, MFTO 605, and MFTO 607 in which they attest to completing the live supervision requirement. Those students who are already in Internship prior to Spring 1, 2023, will not be required to earn 3 hours of live supervision.

In choosing a path of 300 or 500 hours, students should consider many factors. How many hours are required by the state licensure board? What are the benefits to earning more client contact hours? What are the benefits of earning fewer hours but taking an additional content course? Students may consult with the Associate Program director, Dr. Jackie Halstead, when advising is needed. Students will select the path of 300 or 500 hours when applying for Internship (see

Appendices). After a student is approved to begin Internship, any changes to the student's path must be approved by the Clinical Coordinator and the Student Success Advisor.

For students who began the program in Fall 2021 or later, the clinical internship may begin after completion of the first six courses. For students who began the program prior to Fall 2021, the clinical internship may begin after completion of the first four courses. Students are expected to maintain continuous enrollment once entering the Internship courses.

Direct client contact = 500 hours	200 hours of relational therapy + 300 hours of either individual or relational therapy
Direct client contact = 300 hours	100 hours of relational therapy + 200 hours of either individual or relational therapy
Supervision = 100 hours *50 hours must include raw data	

Students are expected to be clinically active once enrolled in Internship courses. In order to progress through the degree plan as designed, students will need to earn an average of 10 client contact hours per week. It is expected that students will need time to build up a caseload. The clinical training portion of the program is divided into six or eight courses, depending on the particular path. Each course is worth 1.5 credit hours each.

- MFTO 602 Internship I
- MFTO 603 Internship II
- MFTO 604 Internship III
- MFTO 605 Internship IV
- MFTO 606 Internship V
- MFTO 607 Internship VI
- MFTO 608 Internship VII*
- MFTO 609 Internship VIII*
- MFTO 698 MFT Internship Continuation I (if needed to earn additional hours)
- MFTO 692 MFT Internship Continuation II (if needed to earn additional hours)
- MFTO 693 MFT Internship Continuation III (if needed to earn additional hours)
- MFTO 617 Internship Capstone Continuation (if needed to complete Capstone requirements)

*Courses will be taken by those students who elect to earn 500 hours.

It is expected that students would earn approximately 75 hours of client contact by the end of Internship II and approximately 75 hours in each remaining Internship course. Beginning in Fall 1, 2022, at the end of MFTO 606, students who have not earned the minimum number of client contact hours listed below will be notified of the necessity to enroll in MFTO Internship Continuation. If Internship Continuation is necessary, students will remain in the course(s) until they have earned the hours needed to progress to MFTO 607.

The suggested benchmarks for earning client contact hours if a student plans to earn 500 hours are:

- End of Internship II: 75 hours
- End of Internship IV: 225 hours
- End of Internship V: 300 or more total hours with a minimum of 150 relational hours are needed to progress to MFTO 607
- End of Internship VIII: minimum 500 hours

The suggested benchmarks for earning client contact hours if a student plans to earn 300 hours are:

- End of Internship II: 75 hours
- End of Internship V: 250 or more total hours with a minimum of 75 relational hours are needed to progress to MFTO 607
- End of Internship VI: minimum 300

Most states require a practicum experience between 9 and 12 months to pursue licensure as a marriage and family therapist. The 9 or 12 credit hours of Internship required by ACU's program should meet most states' practicum requirements. Students who take 9 hours of Internship will enroll in 6 terms; students who elect to take 12 hours of Internship will enroll in 8 terms. However, students are responsible for ensuring that the length of the practicum, along with the required number of clinical hours, meets their state's regulations for licensure. Questions about licensure requirements should be directed to the Associate Program Director, Dr. Halstead. Students who do not earn the required number of clinical hours after 9 or 12 hours will be required to enroll in Internship Continuation. State licensure regulations can be accessed through the [Association of Marriage and Family Therapy Regulatory Boards](#).

Students may earn up to 25% of their client contact utilizing teletherapy. Prior to utilizing teletherapy, students must ensure they are compliant with all state and federal guidelines to deliver services virtually. Students who choose to engage in telehealth on the 500 hour path must earn 150 of the 200 relational hours in person. Students who choose to engage in telehealth on the 300 hour path must earn 75 of the 100 relational hours in person. The table below illustrates

the hours breakdown if a student chooses to earn the maximum number of hours allowed using teletherapy. *Students are not required to earn any client contact hours using teletherapy.*

500 hours of client contact	300 hours of client contact
150 relational in person	75 relational in person
50 relational teletherapy	25 relational teletherapy
225 individual in person	150 individual in person
75 individual teletherapy	50 individual teletherapy
Student conducts 125 hours of teletherapy	Student conducts 75 hours of teletherapy

This Handbook serves as a contract between the online Marriage and Family Therapy program and the student. Please read this Handbook carefully and keep it accessible for quick reference. Students should provide a copy of this Handbook to the MFT local program clinical supervisor, and to the site supervisor if the MFT local program clinical supervisor is off-site; there are sections that specifically apply to their work with you.

Prerequisites, Competencies, and Benchmarks

Prior to enrolling in the Internship sequence, students who began the program in Fall 2021 or later must complete the following prerequisite courses:

- MFTO 601 Pre-Internship
- MFTO 639 Family Theory
- MFTO 641 Family Therapy I
- MFTO 643 Professional Ethics and the Law
- MFTO 645 Systemic Diagnosis & Assessment, MFTO 661 Family Therapy II, or MFTO 663 Cultural Diversity in Family Therapy (these are offered in a 3-course rotation and students must take two of the three courses prior to beginning Internship)

In order to proceed into the clinical training portion of the program, students must earn a minimum cumulative 3.0 GPA in the prerequisite courses; receive a minimum grade of B in MFTO 601 Pre-Internship and complete all aspects of the Internship Checklist (see Appendices).

Before enrolling in MFTO 602 Internship I, students must submit the Internship Site and MFT Local Clinical Supervisor Application to the Clinical Coordinator for approval. Students may not begin accruing hours at the site until both the site and the supervisor have been approved.

Students should begin investigating possible sites as soon as possible once they enter the program. It is not uncommon for this process to take 6-9 months.

Clinical Readiness

To ensure preparedness for the Internship, students will be assessed in MFTO 639, MFTO 641, and MFTO 643 on the items in the table below, taken from the Basic Skills Evaluation Device (BSED). The BSED items are linked to assessment measures (assignments) and those are also mapped to Student Learning Outcomes measured in the particular courses. Any student who fails to meet the target for the assignment (80%) will be required to demonstrate competency through a brief interview or writing assignment.

The Program Director and Associate Program Director will run a grade report from each course in week zero and notify any students who did not meet the target of 80% of the need to remediate prior to beginning Internship.

Students who meet targets on all assignments will be given preliminary approval to begin Internship. Final approval will be given from the Clinical Coordinator.

BSED item	Course	Assessment measure	SLO
Knowledge Base: The trainee has a basic understanding of family systems theory <i>and can communicate clearly and professionally about systems theory in writing.</i>	MFTO 639	W2 DQ2: Basic Assumptions of Systems Theory or Systems Theory and the Circumplex Model	1.1, 1.3
Systems Perspective: The trainee understands and can articulate basic systems concepts. The trainee employs systemic concepts and perspectives, thus showing that he or she is thinking in systemic and contextual terms. Formed hypotheses are systemic. The trainee can articulate the difference between content issues and process issues.	MFTO 639	W2 Assignment 2: The Role of Environment in Systemic Problems or MFTO 639 W5 Discussion 2: Link Between Family and Environment	1.1
Familiarity with Therapy Models: The trainee has a basic	MFTO 641	W1 Assignment 1: Modern Models Introduction or W2 Discussion 1:	1.1

knowledge of family therapy theories <i>and can communicate clearly and professionally about the theories in writing.</i>		Genogram Analysis	
Hypothesizing: The trainee can formulate a systemic hypothesis and can generate general hypotheses as well as theory (or model) specific hypotheses.	MFTO 641	W4 Assignment 1: Structural Family Therapy Case Study Reflection or W3 Assignment 1: Structural Family Therapy Case Study Reflection	1.1
Assessment: The family therapy trainee demonstrates the ability to assess clients through use of genograms, family histories, suicide/depression interviews or inventories, and discussion of SES, employment, school, and developmental stages.	MFTO 641	W5 Assignment 1: Satir Family Therapy Video Reflection or W6 Discussion 2: Systemic Conceptualization using Satir's Theory	1.1
Recognition of Ethical Issues: A marriage and family therapy trainee knows and observes the code of ethics of AAMFT and is familiar with the laws of the state regarding privileged communication, mandatory reporting, and duty-to-warn issues.	MFTO 643	W1 DQ1: Mandatory and Aspirational Ethics W2 DQ1: Duty to Warn W2 Assignment: Informed Consent and Confidentiality Form	6.1

Liability Insurance

Prior to beginning clinical work at a site, all students must have professional liability insurance. As student members of AAMFT, students receive the benefit of liability coverage through their annual membership dues.

Process of Clinical Internship

Students will receive two hours of weekly synchronous group supervision from an ACU faculty member/program clinical supervisor during their Internship courses, in addition to at least one hour of individual supervision from their MFT local program clinical supervisor. The Clinical Coordinator, working with the Graduate Student Success Advisor, will assign the supervision groups with consideration for scheduling needs, balance of the groups, and individual preferences.

Supervision Definitions

Individual supervision is defined as one or two supervisees receiving supervision at the same time. Group supervision is defined as three to eight supervisees receiving supervision at the same time. Two supervisees in the therapy room may receive individual live supervision credit. Supervisees on a reflecting team or observing the session will receive individual credit if no more than two are observing. Three to eight supervisees behind the mirror constitute group supervision for those observing while those in the therapy room (not to exceed two) will receive individual supervision.

Individual Supervision

During the individual supervision session with the MFT local clinical supervisor, the student will be asked to provide file(s) for inspection and documentation of caseload, play recorded sessions of current clients, engage in live supervision sessions, and/or discuss current cases. The student is expected to be prepared for any and all of the above requirements each week in keeping with the expectations of the supervisor. Between scheduled supervision sessions, the intern is required to keep the supervisor updated as to any important changes in a case. The best environment for individual supervision is when the supervisor and student are in the same physical space. However, there are circumstances when it may be necessary for students to attend supervision online. This is permitted; however, students must ensure they are using a HIPAA-secure platform and that client confidentiality is not breached. When a student on the 500 hour path, who is *paying for supervision*, reaches 51 hours of individual supervision, they may discontinue individual supervision with the MFT local clinical supervisor. Those students may meet course requirements for individual supervision by meeting weekly with the site supervisor.

Group Supervision

Weekly group supervision will occur in the Internship courses (MFTO 602-609 and Internship Continuation, if required) and will be conducted with an ACU faculty member/program clinical supervisor. These supervision sessions will be synchronous meetings and the sessions are

considered assignments in the Internship courses. The sessions will convene for 2 hours each week and various topics related to marriage and family therapy will be discussed. Emphasis will be directed toward case management skills, general clinical issues, developing clinical skills, Internship site dynamics, and exploring personal or family issues that impact one's therapeutic effectiveness. The primary focus of the group supervision will be the students' clinical cases and should be presented using observable/raw data (a video recording in which the student demonstrates an MFT theory; the video clip should be an excerpt from an actual session with a relational client system, with the camera trained on the student and the client system). Students are expected to attend each session for the full 2 hours. Supervision meetings may not be recorded.

Most state licensure boards accept the COAMFTE supervisor-to-student ratio of 1:8 in group supervision. However, some states still require a 1:6 ratio. The Clinical Coordinator will review the student's response on the Internship Confirmation Form (see Appendices) to confirm the state where the student plans to seek licensure. Group placement will be based upon that information and the information contained in this [sheet](#). The state supervision ratio information will be updated annually in the Fall 2 term.

Some states permit students to carry over supervision hours earned in a master's program toward the supervision needed for their terminal license. Students should carefully track their individual and group supervision hours throughout the program.

Tracking Observable/Raw Data

Faculty should ensure students understand the importance of carefully tracking the type of supervision (case note, raw data, live). Students can count time spent providing background about the case, specifically reviewing the MFT Group Supervision Case Presentation Form, including the observation of the recorded session, and the discussion about the observed data that occurred after. The student who presented the observable data, and the students who observed the session clip, may count the time spent. Students should not round up to the nearest hour, but should count the actual minutes spent. In Time2Track, students will need to convert the minutes to a percentage. For example, if a student wishes to record 45 minutes of observable/raw data, that would be .75 hours in Time2Track.

Specific explanations for the various modalities of supervision are offered in the table below.

Live	supervision conducted from behind a one-way mirror or over a live video feed
Video	supervision conducted utilizing a video

	portion of a previously recorded session
Case Note	supervision conducted utilizing anecdotal and diagnostic information from the case files

Client Contact Definitions

Client contact is defined as a therapist and client or client system engaged in the process of therapy in the same physical space. The program defines a 50-59 minute therapy hour as 60 minutes. Sessions lasting longer than 60 minutes should be counted by rounding *down* to the nearest 15-minute increment. For example, if a session lasts 67 minutes, the student should document the session as lasting 60 minutes. If the session runs 78 minutes, the student should document the session as lasting 75 minutes.

The following activities are **not** considered client contact:

- Telephonic counseling or contact
- Case conceptualization
- Treatment planning
- Observation of a therapy session
- Updating client charts or records
- Consultation with a treatment team or other provider
- Supervision

Intake assessments may be counted if they are face-to-face processes and the student is actively involved and not merely observing or documenting information.

Specific explanations for the various constellations of therapy are offered in the table below.

Individual	systemic therapy to one person who requests treatment for themselves
Couple (Relational)	systemic therapy to partners who request treatment for themselves or their family
Family (Relational)	systemic therapy to two or more people in a system, related by blood or not, who have defined themselves as a family
Group	systemic group psychotherapy facilitation or co-facilitation

	<p><i>Unless at least one person in the group is related to or in a relationship with another group member, that hour will be counted as individual client contact.</i></p> <p>Students may earn up to 10% of their client contact hours in this constellation.</p>
--	---

**Students may not engage in private practice or earn credit for direct client contact for performing services in the context of their ministerial duties while in Internship.*

***Students may not engage in any client contact in their own homes. In-home therapy at the clients' residence is permitted if it is the modality of the Internship site.*

Holidays and Week Zero

Students should take care to ensure client continuity of care when planning to take vacation, enjoying the December holiday break, or being otherwise absent from the Internship site. The *AAMFT Code of Ethics* (2015) provides the ethical standards for our responsibility to clients in Standard I, Principle 1.11 Non-Abandonment: “marriage and family therapists do not abandon or neglect clients in treatment without making reasonable arrangements for the continuation of treatment” (p. 3). Students should plan to be clinically available *unless* receiving prior approval from the site supervisor; it is not sufficient for the MFT local program clinical supervisor to provide approval for an absence if that supervisor is not affiliated with the internship site.

Guidelines for Choosing a Clinical Placement

Students should consider a variety of factors when discerning and selecting a clinical site. First, the student should determine if the location will provide the type and volume of client contact hours *and* supervision necessary to achieve the program requirements needed for graduation. Specifically, students should determine if there will be an opportunity to earn couple and family hours (200 are needed) and participate in at least one hour of individual supervision per week. Students should also confirm with the site that the placement will last the length of Internship.

When discerning which sites might be a good fit, students should consider the history and reputation of the site (How long has it been established? How is it regarded in the community?) as well as the philosophy of the site. For example, students opting to work in community mental health may be required to utilize cognitive behavioral therapies; students should inquire about the freedom to utilize other methods in addition to those. Or students may wish to work at an agency that primarily provides play therapy. However, the site philosophy may be such that parents are usually not involved in sessions. This would limit the ability to earn relational hours. In addition, students should consider the logistics of commuting to the site. Given that most students earn hours during the afternoon and evenings, students should consider the time commitment to travel to and from the site.

In keeping with the program mission to serve diverse clients and our sense of vocation informed by the principle of hospitality, students are encouraged to seek opportunities to serve underserved populations.

Students should also inquire as to other required tasks such as charting in the client file and attendance at treatment team meetings. As a reminder, these are not considered client contact.

It is *rare* that students will be able to use their current employer as an Internship site. In most situations, the dual relationships are too complex to navigate ethically and professionally. Students should seek out a site that is different from where they are employed.

Finally, the site should have an on-site supervisor who is a licensed mental health clinician who will monitor all clinical work and provide supervision. If the supervisor cannot provide clinical supervision, he or she will still be responsible for monitoring the student's activities while on site. In this event, the student will need to secure a MFT local program clinical supervisor to provide clinical supervision. Students should refer to the Internship Search Process in the Appendices for a more detailed explanation on how to identify and secure a site.

Guidelines for Terminating a Clinical Placement Agreement

There may be reasons a student needs to terminate a clinical placement agreement including a personal move by the student, a change in the referral level or type at the site, or a change in the structure of the clinical placement. The student should first notify the Clinical Coordinator, as well as their ACU faculty/program clinical supervisor regarding the desire to terminate the placement. The Clinical Coordinator will evaluate the request to terminate and make a decision regarding whether the termination should occur, and if so, the process for termination. The Clinical Coordinator will seek input from the clinical placement regarding the request to terminate. Every effort will be made to ensure the termination process adheres to the ethics and integrity of profession.

Guidelines for Selecting a MFT Local Program Clinical Supervisor

When selecting a local program clinical supervisor, students should search for an [AAMFT-Approved Supervisor](#) or an AAMFT-Approved Supervisor Candidate. This will enable students to benefit from systemic supervision at the site. If a supervisor with these credentials cannot be located within a reasonable distance, a licensed marriage and family therapist with demonstrated training in MFT relational/systemic supervision will meet the program's standard. The program adheres to the COAMFTE definition for a program clinical supervisor and defines "demonstration of professional identity as a marriage and family therapist" as having MFT licensure. Please see the explanation below.

MFT Local Clinical Supervisor qualifications include the following:

- a) Demonstration of professional identity as a marriage and family therapist, **and**
- b) Demonstration of training in MFT relational/systemic supervision by one of the following:
 - i) A graduate course in MFT relational/systemic supervision equivalent to three semester-credit hours
 - ii) Postgraduate professional education in MFT relational/systemic supervision of at least 30 clock hours
 - iii) A state established MFT supervisor designation that includes relational/systemic training
 - iv) Designation as an AAMFT Approved Supervisor or AAMFT Approved Supervisor Candidate

Guidelines for Terminating a MFT Local Program Clinical Supervisor Agreement

There may be reasons a student needs to terminate a MFT local program clinical supervisor agreement including a change in the practice profile of the supervisor, an opportunity for the student to reduce out of pocket expense by changing to another supervisor, or a personal move by the student. The student should first notify the Clinical Coordinator, as well as their ACU faculty/program clinical supervisor, regarding the desire to terminate the placement. The Clinical Coordinator will evaluate the request to terminate and make a decision regarding whether the termination should occur, and if so, the process for termination. The Clinical Coordinator will seek input from the MFT local program clinical supervisor regarding the request to terminate. Every effort will be made to ensure the termination process adheres to the ethics and integrity of the MFT profession.

Supervisor Distinctions

ACU Faculty/Program Clinical Supervisor	AAMFT-Approved or Approved Candidate; provides weekly online group supervision for 2 hours within the program
MFT Local Program Clinical Supervisor	AAMFT-Approved or Approved Candidate or, a fully licensed marriage and family therapist with demonstrated training in relational/systemic supervision; provides weekly in-person individual supervision
*Site Supervisor	*Necessary <i>only</i> if the MFT local program clinical supervisor does not practice <i>at</i> the Internship site; responsible for monitoring compliance with policies and procedures of the site and for being physically present and available when the student is clinically active with a client system; must be a licensed mental health clinician

Documentation of Clinical Experience

Students will ensure that all direct client contact and supervision hours (activities) are logged in Time2Track. Hours will be submitted to the MFT local program clinical supervisor for approval, and subsequently approved by the ACU faculty/program clinical supervisor.

Use of Technology

Weekly group supervision will be conducted on Zoom during each Internship course. Zoom is supported by Apple and Windows [operating systems](#) and there is also an [app](#) for Android and iPad devices. Students can learn more about specific computer system requirements on the Zoom [website](#).

It is the student's responsibility to ensure total confidentiality when attending supervision and discussing cases. Therefore, it is essential that students attend supervision in a private area of the home or office. Passersby should not be able to hear the audio or see the screen while students are in supervision. In the event students must attend supervision while traveling or on vacation, every effort must be made to ensure there are no breaches of confidentiality.

Technology Requirements

The table below provides a summary of the necessary requirements for a successful supervision experience.

Broadband internet connection (high speed internet service)	Suitable examples are cable, DSL, or a data card; satellite and dial-up connections will not provide enough bandwidth.
Webcam	Many computers have built-in cameras. In the event a student's computer or device is not equipped with a built-in camera, affordable options exist for external webcams.
Router	To maximize connectivity speed, students should connect directly to the router during supervision if possible. Otherwise, the wireless connection may suffice.
Noise-canceling headset or earbuds	These options will reduce ambient noise and an echo when speaking or playing video.
Digital recording device	Students are expected to present one clip of

	raw data for each supervision session (see Internship syllabus for more details). Care should be taken prior to the beginning of a session to ensure the recorder is trained on the clients and the therapist. Suggestions for devices include video camera with tripod and external mic, or tablet.
--	--

Ethics of Recording and Storage

Students must adhere to the [AAMFT Code of Ethics](#) and site requirements when properly recording videos and disposing of them once they are no longer needed. Specifically, students must take particular note of the following Standards in these situations:

1.12 Written Consent to Record.	“Marriage and family therapists obtain written informed consent from clients before recording any images or audio or permitting third-party observation.”
2.4 Confidentiality in Non-Clinical Activities.	“Marriage and family therapists use client and/or clinical materials in teaching, writing, consulting, research, and public presentations only if a written waiver has been obtained in accordance with Standard 2.2, or when appropriate steps have been taken to protect client identity and confidentiality.”
2.5 Protection of Records.	“Marriage and family therapists store, safeguard, and dispose of client records in ways that maintain confidentiality and in accord with applicable laws and professional standards.”
2.7 Confidentiality in Consultations.	“Marriage and family therapists, when consulting with colleagues or referral sources, do not share confidential information that could reasonably lead to the identification of a client, research participant, supervisee, or other person with whom they have a confidential relationship unless they have obtained the prior written consent of the client, research participant, supervisee, or other person with whom they have a confidential relationship. Information may be shared only to the extent necessary to achieve the purposes of the consultation.”
STANDARD VI TECHNOLOGY-ASSISTED	<i>“Therapy, supervision, and other professional services engaged in by marriage and family therapists take place over an increasing number of technological platforms. There are</i>

PROFESSIONAL SERVICES
(the entire standard applies)

great benefits and responsibilities inherent in both the traditional therapeutic and supervision contexts, as well as in the utilization of technologically-assisted professional services. This standard addresses basic ethical requirements of offering therapy, supervision, and related professional services using electronic means.”

(AAMFT, 2015)

Furthermore, students should attempt to protect confidentiality as much as possible. If storing raw data on an external device, students must have two layers of password protection. Students not using an external device should ensure cloud-hosted storage is disabled on any device used to record and/or store raw data. Students must also ensure that when deleting raw data, the files are actually deleted and not merely stored in a trashcan or the cloud.

Supervision Decorum

Supervision attendance is mandatory for all Internship students and students should approach online group supervision with the same professionalism as they would a live supervision session with their local/site supervisor. This includes logging in promptly as the meeting begins and remaining in the meeting with video on for the entire time, unless previously discussed with the ACU faculty/program clinical supervisor. If a student must miss a supervision session, he or she must seek prior approval from the faculty member.

Delivery of supervision in this manner means that other students will be able to see part of where you live or work. Most webcams have a wide focus which allows other participants to see the background of your surroundings. Students will need to ensure they are comfortable with their surroundings being on camera.

Expectations and Guidelines

Students should be cognizant of and adhere to the following guidelines:

- Remain on camera for the entire session unless instructed to go off camera for bandwidth or other issues.
- Avoid eating on camera.
- Avoid attending to personal hygiene while on camera. If it is necessary to step away for a moment, send a private chat message via Zoom to the faculty member.
- Attend supervision fully clothed and kempt.
- Avoid lying down or reclining.
- Instruct family members, friends, and/or roommates of the confidential nature of the session. Participate in supervision in a private area of the home or office where others will not enter the room or distract.

- Secure animals away from the supervision session.
- Minimize ambient noise by muting when not speaking.

PART III: INFORMATION FOR MFT LOCAL PROGRAM CLINICAL SUPERVISORS and SITE SUPERVISORS

Internship Sequence

The Internship portion of the student's program consists of six or eight Internship courses:

- MFTO 602 Internship I
- MFTO 603 Internship II
- MFTO 604 Internship III
- MFTO 605 Internship IV
- MFTO 606 Internship V
- MFTO 607 Internship VI
- MFTO 608 Internship VII*
- MFTO 609 Internship VIII*

*These courses are taken by students who elect to earn 500 client contact hours.

Students are expected to be clinically active for at least 52 weeks, which allows some time at the outset to become accustomed to the site and gain clients, and toward the end to prepare for the Capstone presentation. During the Internship courses, students are expected to earn either 300 or 500 hours of direct client contact and receive a minimum of 100 hours of supervision, with at least 50 hours of raw data supervision. For those earning 500 hours, 200 must be earned by treating couples and/or families. For those earning 300 hundred hours, 100 must be earned by treating couples and/or families.

Roles of the ACU Faculty/Program Clinical Supervisor

The faculty/program clinical supervisor will be an AAMFT-Approved Supervisor or Supervisor Candidate and will provide systemic group supervision designed to support the MFT local program clinical supervisor. For issues of remediation or coaching, the ACU faculty/program clinical supervisor will collaborate with the MFT local program clinical/site supervisor to provide comprehensive direction to the student.

Roles and Responsibilities of the MFT Local Program Clinical Supervisor

While students will attend weekly group supervision with their ACU faculty/program clinical supervisor via video conference, they are also required to attend weekly supervision with their local program clinical supervisor. Group supervision will offer students a variety of experiences including, but not limited to, a chance to present cases; prepare for Capstone; discuss site issues; and discuss ethical dilemmas and how to respond to them. The supervision format will not allow

for students to present all cases or to receive individualized, in-depth attention. The local program clinical supervisor will provide individual supervision from a relational/systemic perspective and will be expected to sign off on client charts in keeping with site requirements; answer case-specific questions about treatment and MFT theories; and be the point-of-contact for any crises, or ethical and legal situations. In keeping with the best practices of supervision in the field of marriage and family therapy, live supervision is the preferred model. In both group and individual supervision, students should attempt to schedule and coordinate opportunities for live supervision as much as possible.

The local program clinical supervisor will be responsible for four main areas:

1. overseeing the student's clinical training
2. modeling systemic approaches to therapy
3. ensuring students engage in the journey toward cultural humility
4. protecting the public through gatekeeping functions.

These areas are further explained in the following tables.

Area 1

Supervisors will oversee the student's clinical training by:	Modeling and maintaining appropriate boundaries
	Recognizing and attending to issues of power and privilege in an isomorphic fashion
	Coaching the student to develop sound clinical judgment
	Ensuring clients are aware of the student's status as an intern
	Ensuring all clients are provided an informed consent
	Ensuring students provide continuity of care to clients during holiday breaks
	Conducting periodic live supervision
	Utilizing raw data in weekly supervision

Area 2

Supervisors will model the use of systemic approaches to therapy by:	Discussing systemic approaches to therapy and challenging the student to utilize and apply them to cases
	Identifying and discussing isomorphism
	Recognizing contextual issues of diversity and determining how they inform cases and clinical work

Area 3

Supervisors will ensure students engage in the journey toward cultural humility by:	Highlighting issues of power, oppression, and privilege as it relates to sexism, the spectrum of ability, ethnicity, race, ageism, and classism
	Discussing self-of-the-therapist issues of diversity related to treating clients

Area 4

Supervisors will protect the public through gatekeeping by:	Applying the AAMFT Code of Ethics and state statutes to cases where conflict or dilemmas arise and supporting the student in praxis
	Discussing self-of-the-therapist issues related to boundaries and sexual attraction

Finally, supervisors will be expected to inform the student of site policies and introduce them to coworkers and other staff members. This will entail explaining social mores of the site, rules, procedures, and equipping students with the relevant phone numbers for crisis or emergency calls. The supervisor must also ensure the student has a confidential space to counsel that offers privacy and safety or if home-based services are included, then sufficient training in offering home-based therapy, including knowledge of safety planning and crisis procedures.

The supervisor should ensure the student has access to a variety of clients and presenting problems as well as an opportunity to participate in clinical training, staff meetings, or treatment

team meetings. If the MFT local program clinical supervisor is not on site, the site supervisor or their designee should be physically present when the student is seeing clients.

The supervisor should submit an honest and critical evaluation using the Basic Skills Evaluation Device ([BSED](#)) in MFTO 603, MFTO 605, MFTO 607, and MFT Internship Continuation courses MFTO 698, MFTO 692, and MFTO 693 (if needed to earn additional hours). Students earning 500 hours will also be evaluated in MFTO 609. The supervisor's responses to the evaluation will be automatically recorded and sent to the supervisor's email address. The results should be provided to the student and ACU faculty/program clinical supervisor and reviewed during a meeting with the student, ACU faculty/program clinical supervisor, and MFT local clinical supervisor.

Roles and Responsibilities of the Site Supervisor

Some students may be unable to find a MFT local program clinical supervisor who practices at their internship site. Thus, students will also need a site supervisor who will be the primary point of contact regarding policies and procedures.

In this case, the site supervisor will be responsible for five main areas:

1. Inform the student of all expectations, policies, and procedures;
2. Provide students with the relevant phone numbers for crisis or emergency calls;
3. Ensure the student has a confidential space to counsel that offers privacy and safety;
4. Be present and available on site when the student is working clinically with clients;
5. Work collaboratively with the Clinical Supervisor to ensure charts are completed in accordance with ethical standards, state statutes, and HIPAA guidelines.

Supervisor Distinctions

ACU Faculty/Program Clinical Supervisor	AAMFT-Approved or Approved Candidate; provides weekly online group supervision
MFT Local Program Clinical Supervisor	AAMFT-Approved or Approved Candidate or, a fully licensed marriage and family therapist with demonstrated training in relational/systemic supervision; provides weekly in-person individual supervision
*Site Supervisor	*Necessary <i>only</i> if the MFT local program clinical supervisor does not practice <i>at</i> the Internship site; responsible for monitoring

	compliance with policies and procedures of the site
--	---

Evaluation of the Student Intern

The supervisor will evaluate the student using the Basic Skills Evaluation Device (BSED; see Appendices) in MFTO 603, MFTO 605, MFTO 607, and MFT Internship Continuation courses MFTO 698, MFTO 692, and MFTO 693 (if needed to earn additional hours). Students earning 500 hours will also be evaluated in MFTO 609. Students enrolled in Internship Continuation courses will also be evaluated. It is expected that students will grow within a set of developmental criteria. The growth and evaluation should be based upon direct client contact hours and not on hours spent *at* the internship site.

To aid the supervisor in assessing the student, Nelson and Johnson (1999, pp. 23-24) have provided some developmental criteria to operationalize expectations of student development at various stages.

<p>Internship I & II [Beginner (0-75 hours)]</p>	<ul style="list-style-type: none"> ● In this stage, supervisees may require “more direction and structure, clear session plans,” and support for their attempts at theoretical autonomy. ● Supervisees may be eager for supervision or experience anxiety or confusion when placed in new situations. ● Supervisees may not be able to conceptualize more than one theory in practice.
---	---

<p>Internship III - VII [Intermediate (75 - 350-400 hours)]</p>	<ul style="list-style-type: none"> ● In this stage, supervisees may be more comfortable joining with clients. ● The supervisee can “...structure sessions and execute session plans...provide hypotheses or direction for therapy based upon theoretical concepts.” ● The supervisee “can discuss cases
--	--

	<p>from multiple theoretical viewpoints and can evaluate...treatment...progress based on clear goals.”</p> <ul style="list-style-type: none"> ● The supervisee may be “uneven in evaluation of therapy and self.” ● Supervisees may not actively seek or want supervision, preferring instead to ask for help when needed.
--	--

<p>Internship VIII [Advanced (400-500 hours)]</p>	<ul style="list-style-type: none"> ● The supervisee is comfortable in most clinical situations. ● Supervision focuses on the “finer, abstract points of therapy and theory.” ● The supervisor and supervisee “may engage in debate regarding theoretical perspectives and interventions.” ● The supervisee can “evaluate both therapy and self.” ● The supervisee may appear “eager for supervision and express concern that he or she is inadequate as a therapist.”
---	--

Evaluation of the Clinical Internship

At the end of MFTO 603, 605, 607, 609, and Internship Continuation (if required), students will evaluate the internship site using the Evaluation of Clinical Internship form found in the Appendices. Student feedback is valuable and allows the Clinical Coordinator to determine the strengths and growth areas of the site. This information will be distilled, de-identified, and integrated into the Internship Checklist so other students may benefit from the various internship site experiences.

Failure to Meet Standards

Students should refer to the Internship syllabi for specific information regarding the course requirements. Students are also subject to the [ACU Code of Conduct](#), the AAMFT Code of Ethics, and all policies in the ACU Catalog and Handbook. Depending on the level of severity of

the violation, the Program Director and Clinical Coordinator will work with the student to develop a remediation plan or the student may be dismissed from the program.

Internship Grievance Policy

Supervisors with concerns about students' performance in their Internship duties may contact the Clinical Coordinator. The Clinical Coordinator will make a recommendation to the Program Director regarding remediation.

PART IV: PROGRAM EVALUATION PROCESS

At various times throughout the program, students will have an opportunity to evaluate aspects of the program. The data will be aggregated on an annual basis and will be used by the Program Director to make improvements.

Students will evaluate the following areas of the program:

- Resources, Teaching and Learning Practices - Graduating Student Survey
- Courses - At the completion of every course
- Core Faculty, Non-Core Faculty, and Program Clinical Supervisors - At the completion of every course and in the Graduating Student Survey
- Internship Sites - At the completion of MFTO 603, 605, 607, and 609
- MFT Local Program Clinical Supervisors - At the completion of MFTO 603, 605, 607, and 609
- Program Director - Annually via survey

PART V: LICENSURE

To practice as a licensed Marriage and Family Therapist (MFT) in the United States, a professional license from the state, province, or location in which the student intends to practice is required. Each state or province has its own standards for practice and regulates MFTs differently. This [document](#) provides a list of states where this institution has determined that the marriage and family therapy curriculum either meets the educational requirements for licensure or does not meet the educational requirements for licensure as a Marriage and Family Therapist.

Students are encouraged to review the Path to Licensure video in the Internship & Programmatic Resources Canvas module. Additionally, students should take advantage of assignments throughout the curriculum to learn more about their state's licensure requirements.

- Students in MFTO 601 Pre-Internship will complete a licensure plan worksheet, designed to increase student familiarity with the rules in his or her state.
- Students in MFTO 643 Professional Ethics & the Law will complete a professional plan presentation in which they further investigate laws and rules for MFT licensure.
- Students in MFTO 607 Internship VI will complete an AMFTRB practice exam.

The degree program provides clinical internship experiences resulting in up to 500 hours of supervised client contact; up to 200 of those hours are relational hours defined as those hours spent counseling couples and families. Some states require more relational hours which may necessitate enrollment in additional terms of clinical internship.

Students should become familiar with the entities and processes involved in the licensure process. See below for a brief summary.

AMFTRB

The Association for Marriage and Family Therapy Regulatory Boards (AMFTRB) is the “association of state licensing boards governing the regulation of LMFTs.” The association owns and administers the MFT National Exam used by most states (amftrb.org).

Licensing Boards

Each state has a licensure board that is created in statute by the state legislature. Board members are typically appointed by the governor's office. The purposes of the licensing board are to issue and regulate licenses and protect the public. In some states, MFTs have their own licensure board. Other states have composite boards, containing two or more mental and behavioral health

professions in addition to MFTs such as licensed professional counselors or social workers. In the states where the program has made the determination that its curriculum meets the educational requirements for licensure, this does not mean that this is the only requirement to be licensed in that state. Students are responsible for knowing and meeting the licensure requirements for the state in which they intend to practice.

State Statutes/Laws and Rules

The state board's power to issue and regulate licenses comes from legislation that created the board; that legislation is called *statute*. It is not easily changed and requires legislative action. Board *rules* are regulations that clarify and define the statute. The rules provide the details to implement licensing and practice standards. They can be adjusted during a rule review period. In Texas, the statutes and rules about MFTs are found here:

<https://www.bhec.texas.gov/statues-and-rules/index.html>.

Students in need of further assistance should contact the Program Director or Clinical Coordinator.

Appendices

Appendix A

Degree Plans

Requirements for the MMFT, General MFT track, are:

1. Marital and family systems, 3 hours:
MFTO 639 Family Theory/General Systems Theory
2. Marital and family therapy, 15 hours:
MFTO 610 Couples Therapy
MFTO 641 Family Therapy I
MFTO 645 Systemic Diagnosis and Assessment
MFTO 651 Sexual Therapy
MFTO 661 Family Therapy II
3. Individual development, 9 hours:
MFTO 662 Family Life Cycle
MFTO 663 Cultural Diversity in Marriage and
Family Therapy
MFTO 665 Therapy Across the Life-Cycle
4. Professional studies, 3 hours:
MFTO 643 Professional Ethics and the Law
5. Supervised clinical practice, 9 or 12 hours:
MFTO 602, 603, 604, 605, 606, 607, 608*, and 609*
6. Research, 3 hours:
MFTO 615 Research Methods in Family Therapy
7. Additional courses, 9 hours:
MFTO 697 Ecology of Trauma and Crisis for the Therapist
MFTO 634 Addictive Disorders

MFTO 601 Pre-Internship

8. Two electives from a related area in the university with the approval of the Program Director.**

9. Capstone Project.

*Those students who elect to earn 500 hours of client contact will take MFTO 608 and MFTO 609.

**Those students who elect to earn 300 hours of client contact will take three electives.

Requirements for the MMFT, Child and Adolescent Therapy Track, are:

1. Marital and family systems, 3 hours:
MFTO 639 Family Theory/General Systems Theory
2. Marital and family therapy, 18 hours:
MFTO 610 Couples Therapy
MFTO 641 Family Therapy I
MFTO 645 Systemic Diagnosis and Assessment
MFTO 651 Sexual Therapy
MFTO 661 Family Therapy II
MFTO 634 Addictive Disorders
3. Individual development, 6 hours:
MFTO 662 Family Life Cycle
MFTO 663 Cultural Diversity in Marriage and
Family Therapy
4. Professional studies, 3 hours:
MFTO 643 Professional Ethics and the Law
5. Supervised clinical practice, 9 or 12 hours:
MFTO 602, 603, 604, 605, 606, 607, 608*, and 609*
6. Research, 3 hours:
MFTO 615 Research Methods in Family Therapy
7. Child and Adolescent Therapy , 12 hours**:
MFTO 622 Systemic Play Therapy
MFTO 624 Family Therapy with Children and Adolescents
MFTO 697 Ecology of Trauma and Crisis for the Therapist
MFTO 628 Assessment and Treatment of Child and Adolescent Disorders
8. Additional courses, 3 hours:
MFTO 601 Pre-Internship
9. Capstone Project.

*Those students who elect to earn 500 hours of client contact will take MFTO 608 and MFTO 609.

**Those students who elect to earn 300 hours of client contact will take an additional elective.

Requirements for the MMFT, Treatment of Trauma track, are:

1. Marital and family systems, 3 hours:
MFTO 639 Family Theory/General Systems Theory
2. Marital and family therapy, 18 hours:
MFTO 610 Couples Therapy
MFTO 641 Family Therapy I
MFTO 645 Systemic Diagnosis and Assessment
MFTO 651 Sexual Therapy
MFTO 661 Family Therapy II
MFTO 634 Addictive Disorders
3. Individual development, 6 hours:
MFTO 662 Family Life Cycle
MFTO 663 Cultural Diversity in Marriage and
Family Therapy
4. Professional studies, 3 hours:
MFTO 643 Professional Ethics and the Law
5. Supervised clinical practice, 9 or 12 hours:
MFTO 602, 603, 604, 605, 606, 607, 608, and 609
6. Research, 3 hours:
MFTO 615 Research Methods in Family Therapy
7. Treatment of Trauma, 12 hours**:
MFTO 630 Trauma Intervention Models
MFTO 655 Systemic Trauma and Violence
MFTO 697 Ecology of Trauma and Crisis for the Therapist
MFTO 657 Assessment and Treatment of Family Violence
8. Additional courses, 3 hours:
MFTO 601 Pre-Internship
9. Capstone Project.

*Those students who elect to earn 500 hours of client contact will take MFTO 608 and MFTO 609.

**Those students who elect to earn 300 hours of client contact will take an additional elective.

Requirements for the MMFT, Therapy with Military Families track, are:

1. Marital and family systems, 3 hours:
MFTO 639 Family Theory/General Systems Theory
2. Marital and family therapy, 18 hours:
MFTO 610 Couples Therapy
MFTO 641 Family Therapy I
MFTO 645 Systemic Diagnosis and Assessment
MFTO 651 Sexual Therapy
MFTO 661 Family Therapy II
MFTO 634 Addictive Disorders
3. Individual development, 6 hours:
MFTO 662 Family Life Cycle
MFTO 663 Cultural Diversity in Marriage and
Family Therapy
4. Professional studies, 3 hours:
MFTO 643 Professional Ethics and the Law
5. Supervised clinical practice, 12 hours:
MFTO 602, 603, 604, 605, 606, 607, 608*, and 609*
6. Research, 3 hours:
MFTO 615 Research Methods in Family Therapy
7. Therapy with Military Families, 12 hours**:
MFTO 682 Dynamics of Military Families
MFTO 684 Family Therapy with Military Families
MFTO 697 Ecology of Trauma and Crisis for the Therapist
MFTO 657 Assessment and Treatment of Family Violence
8. Additional courses, 3 hours:
MFTO 601 Pre-Internship
9. Capstone Project.

*Those students who elect to earn 500 hours of client contact will take MFTO 608 and MFTO 609.

**Those students who elect to earn 300 hours of client contact will take an additional elective.

A sample degree plan is illustrated below. Course offerings are subject to the University Registrar. Students are reminded to remain in regular contact with their Student Success Advisor and Financial Aid Specialist throughout the program, especially if there are any deviations to the degree plan due to change in student status with the University such as an academic break, course withdrawal, retake, or a deferred entrance into the Internship. Any such change in student status may impact progression through the degree plan.

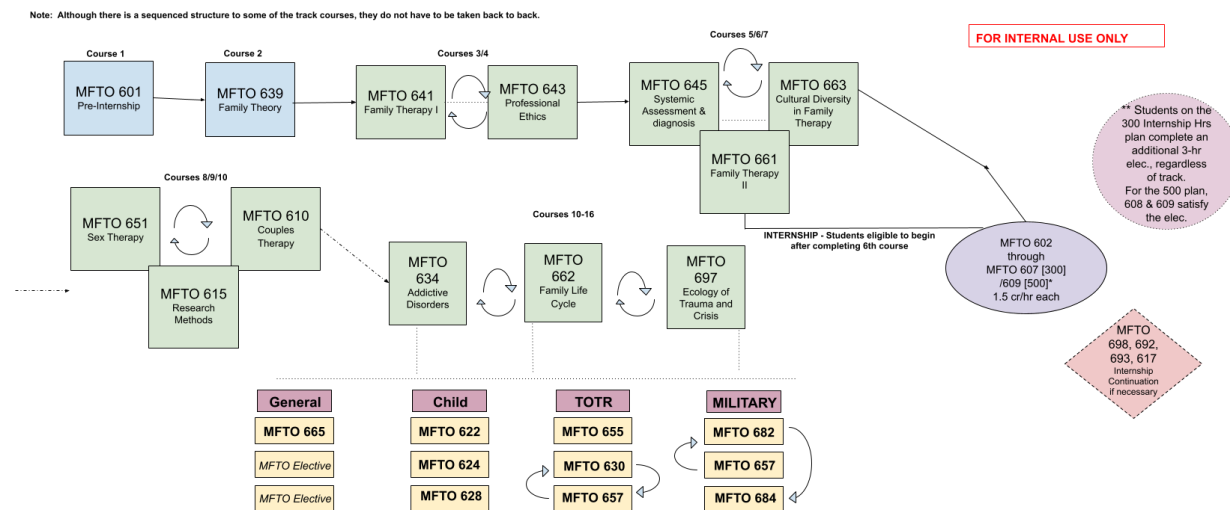

Appendix B

Student Learning Outcomes Assessment Schedule

(Updated February 2024)

Student Learning Outcomes	Assessment Measure
Program Outcome #1: Demonstrate competency in the practice of relational/systemic therapy with diverse couples, families, and individuals.	
1.1 Understand foundational systems, concepts, theories, and techniques of marital, couple, and family therapy. (Y1)	Competency Target = average score of 80% in each section, Ideal Target = average score of 90% in each section <ul style="list-style-type: none"> ● Content and Process Discussion Question - MFTO 601 ● Terms Two General Systems Theory- MFTO 639 ● Paradoxical Intervention - MFTO 641 ● Micro-Interventions in a Transcript - MFTO 661
1.2 Recognize contextual and systemic dynamics with a commitment to diversity and inclusion. (Y1)	Competency Target = average score of 80% in each section, Ideal Target = average score of 90% in each section <ul style="list-style-type: none"> ● Being the Minority Assignment & Action Plan Assignment - MFTO 663 Competency Target = average score of 80% for the rubric item: Contextual and systemic dynamics (e.g., gender, age, socioeconomic status, culture/race/ethnicity, sexual orientation, spirituality, religion, larger systems, social context) are discussed as they pertain to case study. Ideal Target = average score of 90%. Data will be aggregated for the assessment year. <ul style="list-style-type: none"> ● Capstone Theory of Change Paper - MFTO 607
1.3 Understand principles of human development, human sexuality, gender development, psychopathology, psychopharmacology, couples processes, & family development processes. (Y1)	Competency Target = average score of 80% in each section, Ideal Target = average score of 90% in each section <ul style="list-style-type: none"> ● Sexuality and Development Theory Paper - MFTO 651 ● Cinematherapy Analysis - MFTO 662
1.4 Distinguish differences between content and process issues. (Y1)	Competency Target = average score of 80% in each section, Ideal Target = average score of 90% in each section

	<ul style="list-style-type: none"> • Bowen Family Therapy Video Reflection Assignment- MFTO 641 <p>Competency Target = average score of 80% for the rubric item: Case note or progress note are 200-350 words in length word document, formatted from the choice of DAP or SOAP, and written based upon the session in the demonstration video. Ideal Target = average score of 90%.</p> <ul style="list-style-type: none"> • Case Note Practice as part of the Mutualization Role Play Assignment - MFTO 601
Program Outcome #2: Demonstrate competency in assessing, hypothesizing and diagnosing.	
2.1 Develop systemic hypotheses and assess family history and dynamics from a systemic perspective. (Y1)	<p>Competency Target = average score of 80% in each section, Ideal Target = average score of 90% in each section</p> <ul style="list-style-type: none"> • Theory of Change Discussion - MFTO 602 • Raw Data Presentation - MFTO 603
2.2 Recognize contraindications for couples and family therapy. (Y2)	<p>Competency Target = average score of 80% in each section, Ideal Target = average score of 90% in each section</p> <ul style="list-style-type: none"> • Developing an Annotated Bibliography Assignment - MFTO 610
2.3 Understand behavioral health disorders including the epidemiology, etiology, phenomenology, effective treatments, course, & prognosis. (Y2)	<p>Competency Target = average score of 80% in each section, Ideal Target = average score of 90% in each section</p> <ul style="list-style-type: none"> • Recovery Meeting Analysis - MFTO 634 • Case Study: Diagnosis I - MFTO 645 • Diagnosing Sexual Dysfunction Paper - MFTO 651
2.4 Systematically integrate client reports, observations of client behaviors, client relationship patterns, reports from other professionals, results from testing procedures, and interactions with client to guide the assessment process. (Y2)	<p>Competency Target = average score of 80% in each section, Ideal Target = average score of 90% in each section</p> <ul style="list-style-type: none"> • Suicide Assessment Report - MFTO 645 • Treatment Planning with Integrative Behavioral Couple Therapy - MFTO 610 • Abbreviated Raw Data Capstone Presentation - MFTO 605
Program Outcome #3: Demonstrate competency in designing and conducting relational/systemic treatment.	
3.1 Know which models, modalities, and/or techniques are most effective for presenting problems and apply them to diverse couples and families.	<p>Competency Target = average score of 80% in each section, Ideal Target = average score of 90% in each section</p> <ul style="list-style-type: none"> • SFBT Therapy Questions - MFTO 661

(Y2)	<ul style="list-style-type: none"> ● Family Assessment Report - MFTO 645 ● Practicing Emotionally Focused Couple Therapy (EFCT) with a Case Study - MFTO 610 ● Raw Data Presentation - MFTO 604, MFTO 605 ● Capstone Theory of Change Draft - MFTO 606 <p>Competency Target = average score of 80% for the rubric item: Implement interventions that are consistent and congruent with model of therapy and articulates goals of the treatment plan in the case study. Ideal Target = average score of 90%. Data will be aggregated for the assessment year.</p> <ul style="list-style-type: none"> ● Capstone Theory of Change Paper - MFTO 607
3.3 Integrate client feedback, assessment, contextual information, and diagnosis with treatment goals and plan. (Y2)	<p>Competency Target = average score of 80% in each section, Ideal Target = average score of 90% in each section</p> <ul style="list-style-type: none"> ● Full Mock Capstone - MFTO 606 <p>Competency Target = average score of 80% for the rubric item: Develop hypotheses regarding relationship patterns, their bearing on the presenting problem, and the influence of extra-therapeutic factors on client systems. Ideal Target = average score of 90%. Data will be aggregated for the assessment year.</p> <ul style="list-style-type: none"> ● Capstone Clinical Presentation - MFTO 607
Program Outcome #4: Demonstrate competency in evaluating ongoing process and terminating treatment.	
4.2 Develop measurable outcomes, treatment goals, treatment plans, and after-care plans with an eye toward termination. (Y3)	<p>Competency Target = average score of 80% in each section, Ideal Target = average score of 90% in each section</p> <ul style="list-style-type: none"> ● Raw Data Presentation - MFTO 604 ● Raw Data Presentation - MFTO 605
Program Outcome #5: Demonstrate competency in managing crisis situations.	
5.1 Understand how crisis and trauma impact the family system. (Y3)	<p>Competency Target = average score of 80% in each section, Ideal Target = average score of 90% in each section</p> <ul style="list-style-type: none"> ● Cinematherapy - MFTO 697 ● Cycle of Trauma Discussion Question - MFTO 697

5.2 Manage risks, crises, and emergencies using recognized standards of practice. (Y3)	Competency Target = average score of 80% in each section, Ideal Target = average score of 90% in each section <ul style="list-style-type: none"> ● Develop an Annotated Bibliography Assignment - MFTO 610 ● Trauma Response Treatment Plan - MFTO 697
Program Outcome #6: Demonstrate competency in maintaining ethical, legal, and professional standards.	
6.1 Know state, federal, & provincial laws & regulations as well as professional ethics and standards for clinical practice and research. (Y1)	Competency Target = average score of 80% in each section, Ideal Target = average score of 90% in each section <ul style="list-style-type: none"> ● Duty to Warn Discussion Question - MFTO 643 ● Informed Consent and Confidentiality Assignment - MFTO 643 ● Professional Plan Assignment - MFTO 643
6.2 Understand the process of making an ethical decision and recognize dilemmas in which ethics, laws, and professional liability apply. (Y1)	Competency Target = average score of 80% in each section, Ideal Target = average score of 90% in each section <ul style="list-style-type: none"> ● Ethics in Difficult and Dangerous Situations Paper - MFTO 643
6.3 Monitor attitudes, personal well-being, personal issues, and personal problems and ascertain their influence on ethical practice. (Y1)	Competency Target = average score of 80% in each section, Ideal Target = average score of 90% in each section <ul style="list-style-type: none"> ● Faith, Values, Morals, and Ethics Assignment- MFTO 643
6.4 Articulate a personal spiritual/religious perspective on the discipline of marriage and family therapy. (Y2)	Competency Target = average score of 80% in each section, Ideal Target = average score of 90% in each section <ul style="list-style-type: none"> ● Personal Spirituality and the Practice of MFT - MFTO 662 ● Survivor Case Study Video - MFTO 697 ● A Theology of Marriage - MFTO 639 ● Spirituality in Therapy - MFTO 601
Program Outcome #7: Demonstrate competency in understanding, critically evaluating, and clinically applying relational/systemic research.	
7.1 Understand the relationship between research and evaluative practices. (Y3)	Competency Target = average score of 80% in each section, Ideal Target = average score of 90% in each section <ul style="list-style-type: none"> ● Theory, Research, and Evaluation Discussion Question - MFTO 615

- | | |
|--|--|
| | <ul style="list-style-type: none">● Essential Elements of Writing Discussion Question - MFTO 615 |
|--|--|

Note on the triennial assessment cycle:

During year one, SLOs assessed are indicated by Y1.

During year two, SLOs assessed are indicated by Y2

During year three, SLOs assessed are indicated by Y3.

For instance, during the assessment collection in May of 2020 (which is year two in the cycle), information from the related courses will be collected for sections taught in the preceding 6 parts of term.

Appendix C

Basic Skills Evaluation Device

Instructions for Supervisors: The [Basic Skills Evaluation Device](#) (BSED) was developed by Nelson and Johnson (1999) from data gathered to determine the basic skills for family therapy that are essential for beginning level trainees. The device serves several purposes, including that of evaluating therapist trainees in their first 500 hours of training. The scale is used at the experience level of the trainee. That is, “meets expectation” means “in your experience, compared with other trainees with this level of experience and training,” which may differ from supervisor to supervisor. Included are descriptions for each training dimension based on data from the Basic Family Therapy Skills Project. Please use these descriptions when evaluating your trainees. Included in the device is a non-generic theory section that you may want to use, filling in the blank for the theory the trainee is currently working with. Evaluate each trainee using your best judgment from the descriptions given plus your subjective ideas about each item.

Instructions for Students: The Basic Skills Evaluation Device (BSED) was developed by Nelson and Johnson (1999) from data gathered to determine the basic skills for family therapy that are essential for beginning level trainees. The device serves several purposes, including that of evaluating therapist trainees in their first 500 hours of training. The scale is used at the experience level of the trainee. Included are descriptions for each training dimension based on data from the Basic Family Therapy Skills Project. Please use these descriptions when evaluating yourself. Included in the device is a non-generic theory section that you may want to use, filling in the blank for the theory you are currently working with. Evaluate your clinical skills based on the descriptions given plus your subjective thoughts about each item.

General Guidelines Regarding Developmental Levels

Beginner: First 50-75 hours of experience, less perhaps, if under intensive live supervision. The beginner will need more direction and structure, clearer session plans, and more freedom to go in a direction that may seem less productive but which follows the trainee’s plan for the session and the supervisor’s plan for what the trainee is currently working on. For example, the supervisor may see an opportunity for a paradoxical or solution-oriented approach, but the trainee may be working on structuring the session with parents and children. The trainee can discuss case material based on one theoretical perspective but may get confused if trying to use more than one. The trainee is eager for supervision and may feel confused or anxious in new situations.

Intermediate: Between 50 or 75 hours of experience and 350 or 400 hours. The trainee is comfortable joining with clients, can structure sessions and execute session plans, and is able to

provide hypotheses or direction for therapy based on theoretical concepts. The trainee can be flexible during a session, changing the session plan easily and with little confusion. The trainee can discuss cases from multiple theoretical viewpoints and evaluate both treatment and self-as-therapist progress based on clear goals. The trainee may be uneven in evaluations of therapy and self. The trainee benefits from supervision but may appear at times to not want supervision, wanting instead to be allowed to work on one's own unless asking for help.

Advanced: Between 350 or 400 hours of experience and 500 hours. The trainee is comfortable and does well in most therapy situations, managing most case situations smoothly and professionally. Supervision focuses on microskills and finer, abstract points of therapy and theory. The supervisor and trainee may engage in debate regarding theoretical perspectives and interventions. The trainee is able to evaluate both therapy and self. The trainee may appear eager for supervision and may express concern that he or she is inadequate as a therapist, unable to evaluate progress in therapy or supervision.

Conceptual Skills

Knowledge Base: The trainee has a basic understanding of family systems theory. The trainee is able to articulate principles of human developmental, family developmental, and family life cycle issues pertaining to the case. The trainee communicates an understanding of human interaction and normal family processes. The trainee can articulate how gender, culture, and class have an impact on the client and on therapeutic issues (including interaction with one's own gender, culture/ethnicity, and class). The trainee is able to determine and work within the clients' worldview. The trainee has an understanding of human sexuality. The trainee has a knowledge of assessment strategies (e.g., interviewing skills, various assessment devices, DSM).

Systems Perspective: The trainee understands and can articulate basic systems concepts. When talking about client problems, the trainee employs systemic concepts and perspectives, thus showing that he or she is thinking in systemic and contextual terms. Formed hypotheses are systemic. The trainee can articulate the difference between content issues and process issues. The trainee can recognize hierarchy problems.

Familiarity with Therapy Models: The trainee has a basic knowledge of family therapy theories. The trainee's goals, hypotheses, session plans, interventions, and evaluation strategies for terminating therapy are all linked to a specific employed and articulated therapeutic model (which may be an integrated model). The trainee also recognizes his or her own perceptions, client resources, and links between problems and attempted solutions.

Self as Therapist: The trainee can articulate his or her own model of therapy. The trainee is also aware of how his or her communication style impacts therapy and is curious in learning about himself or herself. The trainee is aware of and able to manage his or her own anxiety in therapy. In talking about cases the trainee is able to reframe or positively connote issues from cases for himself or herself. The trainee has an understanding of how to use a sense of humor in therapy. The trainee recognizes her or his ability to be flexible and curious and to think critically and analytically, expressing authenticity and accepting feedback. The trainee is able to recognize how her or his own developmental or other issues interact in therapy.

Perceptual Skills

Recognition Skills: The trainee shows the ability to recognize hierarchies, boundaries, dynamics of triangling, family interaction, and family behavioral patterns. The trainee can also recognize gender, ethnic, cultural, and class issues in client dynamics and in therapy. The trainee is able to recognize clients' coping skills and strengths and can understand dynamics and patterns in presenting problems. The trainee recognizes how patterns associated with presenting problems may be similar to other patterns of interaction in clients' lives. The trainee recognizes and can articulate her or his impact as part of the client/therapy system.

Hypothesizing: The trainee can formulate a systemic hypothesis and can generate general hypotheses as well as theory (or model) specific hypotheses. The trainee can formulate long- and short-term treatment plans based on hypotheses. The trainee is able to distinguish process from content at an appropriate level and include process issues in hypotheses. The trainee reframes patterns and problems appropriately.

Integration of Theory and Practice: The family therapy trainee is able to articulate theory as it is applied in practice, utilizing concepts appropriately, and describing interventions that fit with the theory and hypotheses. If using an integrated theory, the trainee is able to evaluate the appropriateness (positives and negatives) for a theory or integrated theory using concrete data from therapy cases.

Executive Skills

Joining: A trainee skilled in the technique of joining is able to engage each family member in a therapeutic alliance and relationship by establishing rapport through clear communication that conveys a sense of competency, authority, and trustworthiness while at the same time demonstrating empathy, warmth, caring, and respect. The trainee is capable of gathering information without making the client feel interrogated, laying down the ground rules for

therapy, and setting up a workable treatment contract by exploring the client's expectations, points of view, and preparedness to make changes. These goals are accomplished in conjunction with setting appropriate boundaries and avoiding triangulation.

Assessment: The family therapy trainee demonstrates the ability to assess clients through use of genograms, family histories, suicide/depression interviews or inventories, and discussion of SES, employment, school, and developmental stages. The trainee is familiar and skilled in basic interviewing techniques and strategies. Assessment is formulated and appropriate to an articulated theory of change. The trainee is able to clarify the presenting problem, explore previous solutions to the problem, gather information regarding sequences and patterns in the family, and determine the strengths and resources that the family brings to therapy. Assessment strategies are sensitive to gender, race, and cultural issues.

Hypothesizing: The trainee exhibits the ability to formulate multiple hypotheses about a case based on articulated principles of a theory of change. She or he can develop treatment plans which include a rationale for intervention based on hypotheses; set clear, reachable goals in consultation with the family; focus the treatment toward a therapeutic goal; and modify the existing case plan when appropriate.

Interventions: The trainee demonstrates an understanding of intervention techniques by structuring interventions that defuse violent or chaotic situations, deflect scapegoating and blaming, and interrupt negative patterns and destructive communication cycles. The ability to intervene also includes appropriately challenging clients on their position, explicitly structuring or directing interactions among family members, and helping families establish boundaries. The trainee is able to elicit family/client strengths and utilize them in both session discussions and homework assignments. Other interventions that illustrate skill include normalizing the problem when appropriate, helping clients develop their own solutions to problems, giving credit for positive changes, reframing, and appropriately using self-disclosure. The trainee uses theory-specific interventions appropriately and is able to articulate a rationale for these interventions.

Communication Skills: Communication skills are demonstrated by active listening and reflecting; the use of open-ended questions; and short, specific, and clear oral forms of communication. The trainee's body language should convey a relaxed state and match the tone of the conversation. The trainee is also able to coach clients in learning communication skills rather than merely "lecturing" and instructing.

Personal Skills: Personal skills that are important for a successful therapy trainee to possess include a desire to be a family therapist, intelligence, curiosity, common sense, self-direction,

commitment, patience, empathy, sensitivity, flexibility, the ability to manage his or her anxiety, authenticity, expression of a caring attitude, and acceptance of others. The trainee should also exhibit warmth, a sense of humor, a non defensive attitude, congruency, the ability to take responsibility for his or her mistakes, the ability to apply his or her own personal mode of therapy, and possess no debilitating personal pathology. The trainee demonstrates emotional maturity and the ability to be self-reflexive. The trainee demonstrates an appropriate attitude of expertness toward clients, congruent with her or his theory of change.

Session Management: The trainee is able to manage the therapy process by effectively introducing clients to the therapy room, explaining equipment and setting, if necessary, and explaining the policies and procedures of the agency/clinic. The trainee is able to engage the family in therapeutic conversation, controlling the flow of communication as per her or his therapy plan. The trainee is able to manage intense interactions appropriately, demonstrating skill at both escalating and deescalating intensity at appropriate times. The trainee is able to manage time, finishing sessions as scheduled, and is able to schedule further appointments, consultations, and referrals smoothly and effectively. The trainee is able to collect fees in an appropriate manner.

Professional Skills

Supervision: The trainee attends supervision meetings as scheduled and is prepared to discuss cases with colleagues, to formally present her or his own case, and to present audio or video material as requested. The trainee is respectful and positive about other trainees' cases and presentations, and is helpful and not demeaning about a fellow trainee's skills. The trainee makes use of supervision by accepting and utilizing supervisory feedback.

Recognition of Ethical Issues: A marriage and family therapy trainee knows and observes the code of ethics of AAMFT and is familiar with the laws of the state regarding privileged communication, mandatory reporting, and duty-to-warn issues. The trainee follows the supervisor's policies regarding reporting and consulting with the supervisor and/or other authorities; the trainee appropriately uses supervision and consultation regarding ethical issues. The trainee avoids potentially exploitative relationships with clients and other trainees. The trainee deals appropriately with his or her own issues as they affect therapy and is willing to take responsibility for her or his own actions.

Paperwork: The trainee maintains case files appropriately and follows clinic procedures for paperwork in a timely manner.

Professional Image: The trainee dresses appropriately according to the standards of the setting. The trainee is able to present an aura of confidence without arrogance and presents herself or himself to other professionals in an appropriate manner. The trainee is on time for sessions and supervision and treats staff with respect.

Professional Conduct: The trainee has the ability to initiate and maintain appropriate contact with other professionals along with maintaining a personal professional image. The trainee does not publicly denigrate or criticize colleagues. The trainee consults with professionals and others involved with cases appropriately, with appropriate signed releases, and in a professional manner, always keeping the clients' welfare foremost. The trainee shows the ability to handle unexpected and crisis situations with poise and skill, using consultation when appropriate. The trainee is punctual with therapy sessions and other professional meetings. The trainee follows clinic policies in setting and collecting fees.

Evaluation Skills

Therapy: A trainee skilled in evaluating therapy is able to verbalize the thoroughness of assessment; the link between theory, assessment, and hypotheses/interventions; the effectiveness of interventions; and how well the objectives of therapy have been met in terms of both the clients' goals and the therapist's perspective and analysis. The trainee can articulate aspects of the clients' feedback in relation to assessment and intervention. The trainee is able to articulate links between conceptual, perceptual, interventive, and outcome data.

Self: The trainee therapist is skilled in evaluating himself or herself in terms of skills: conceptual, perceptual, executive, professional, and evaluative. The trainee is able to recognize signs in himself or herself that contribute to the ongoing understanding and analysis of the case and is able to articulate personal issues that may be interacting in therapy. The trainee is not unduly defensive about feedback, but is able to integrate multiple perspectives and incorporate them into a plan for enhancing his or her development as a family therapist. The trainee works with the supervisor in an ongoing evaluation of therapy skills and strives to improve areas that require it and, at the same time, clearly articulate strengths in behavioral terms.

Theory of Choice: The previous skill areas were generic; i.e., they apply across theoretical models of intervention. This section is for the trainee therapist and supervisor to use to evaluate the trainee's growing knowledge and expertise in a model or theory that is identified by the supervisor and trainee together. The trainee is able to identify assumptions and concepts of the theory, the primary techniques used in the theory, the role of the therapist, and evaluation strategies. The trainee is able to use the concepts and interventions in practice, identifying data to

the supervisor that illustrate the concepts. The trainee is able to recognize and identify the strengths and weaknesses of the theory as used in practice.

BASIC SKILLS EVALUATION DEVICE

Therapist:

Date:

Supervisor:

Experience Level:

	Inadequate Information	Deficient	Below Expectation	Meets Expectation	Exceeds Expectation	Exceptional Skills
Conceptual Skills						
Knowledge Base						
Systems Perspective						
Familiarity with Therapy Model						
Self as Therapist						
Comments:						
Perceptual Skills						
Recognition Skills						
Hypothesizing						
Integration of Theory into Practice						
Comments:						

Executive Skills						
Joining						
Assessment						
Hypothesizing						
Interventions						
Communication Skills						
Personal Skills						
Session Management						
Comments:						
Professional Skills						
Supervision						
Recognition of Ethical Issues						
Paperwork						
Professional Image						
Professional Conduct						
Comments:						
Evaluation Skills						
Evaluation of Therapy						
Evaluation of Self						
Comments:						

Theory (use preferred model)						
Knowledge of Theory						
Utilizes Theory in Practice						
Recognizes Strengths & Weaknesses of Theory						
Comments:						

Appendix D

Capstone Project Evaluation Rubrics

Theory of Change Paper

1-1.99 = Fails to meet minimum expectations

2-2.99 = Meets some but not all expectations

3-3.99 = Meets expectations

4 = Exceeds expectations

Expectation	Score
1. Literature review explains systemic change in therapy	
2. Foundational aspects of model are described	
3. Interventions are consistent and congruent with model of therapy; goals of the treatment plan are systemic (SLO 3.1)	
4. Spiritual considerations of change are described	
5. The integration includes sound theoretical support, a philosophical explanation of change that is congruent with the theory or model of choice, and is supported by a systemic lens	
6. Ethical practice is demonstrated through a discussion of issues relevant to the case	
7. Contextual and systemic dynamics (e.g., gender, age, socioeconomic status, culture/race/ethnicity, sexual orientation, spirituality, religion, larger systems, social context) are discussed as they pertain to case study (SLO 1.2)	
8. Writing is scholarly, professional in tone, and free of grammatical and editing errors; references are from primary sources; APA formatting is free of mistakes and adheres to the current edition of the APA manual. The paper is 15-20 pages long, excluding references.	
Feedback:	

Clinical Presentation

1-1.99 = Fails to meet minimum expectations

2-2.99 = Meets some but not all expectations

3-3.99 = Meets expectations

4 = Exceeds expectations

Expectation	Score
1. Demonstrates knowledge of general systems theory, cybernetics, and the chosen MFT theory with regard to assumptions of the model, role of the therapist, and appropriate interventions	
2. Stages of therapy are described and interventions are demonstrated in clips from multiple sessions; total clips are between 10-20 minutes long	
3. Hypotheses regarding relationship patterns, their bearing on the presenting problem, and the influence of extra-therapeutic factors on client systems are offered; hypotheses are congruent with model of therapy (SLO 3.3)	
4. Ethical and legal issues are described and decisions follow the process from an ethical-decision making model; referrals and consultations are described	
5. Diagnoses and other diagnostic impressions are offered for members of the system according to the <i>DSM-5-TR</i>	
6. Issues of diversity are identified and described	
7. The progression of the case is described; the quality of therapy is described	
Feedback:	

Appendix E

Internship Checklist Of Prerequisites

Internship Checklist of Prerequisites
Submit proof of liability insurance to Clinical Coordinator through membership in AAMFT
Submit Internship Site Application <i>and</i> MFT Local Program Clinical Supervisor Application to Clinical Coordinator no later than week 4 of the term prior to anticipated start
Agree to use Informed Consent at Site
Complete background check, if required by Site
Receive approval via email from Clinical Coordinator for Site Placement and MFT Local Program Clinical Supervisor
Complete first 6 courses (18 hours) and be in good standing
Satisfy all aspects of Clinical Readiness
Complete Internship Advising Confirmation Form

Appendix F

MFT Local Program Clinical Supervisor Application

The application can be found here: <https://forms.gle/F2CSYaVUJ4HXnx5s8>

All applications must be submitted through Google forms.

Appendix G

Internship Site Application

The application can be found here: <https://forms.gle/fntUjTxptni2QB6v9>
All applications must be submitted through Google forms.

Appendix H

Tracking Client Contact And Supervision

Students will create their own account with Time2Track (at no additional cost to the student), an online clinical tracking and approval management system (<https://acrobat.adobe.com/link/review?uri=urn:aaid:scds:US:7ccd0f4a-786e-30e5-807e-7067a751fe50>). Students should discuss any questions with the Clinical Coordinator. The following is a list of client contact and supervision activities in Time2Track:

Relational Direct Client Type

Couples Therapy (In-Person) couple
 Couples Therapy (Telehealth) couple
 Family Therapy (In-Person) family
 Family Therapy (Telehealth) family
 Group Family Therapy (In-Person) group
 Group Family Therapy (Telehealth) group
 Group Couples Therapy (In-Person) group
 Group Couples Therapy (Telehealth) group

Individual Direct Client Type

Individual Therapy (In-Person) individual
 Individual Therapy (Telehealth) individual
 Group Therapy - Individual (In-Person) group
 Group Therapy - Individual (Telehealth) group

Supervision Client Type

Individual Case Report (In-Person)
 Individual Case Report (Telehealth)
 Individual Raw Data - Live (In-Person)
 Individual Raw Data - Live (Telehealth)
 Individual Raw Data - Video (In-Person)
 Individual Raw Data - Video (Telehealth)
 Group Case Report (In-Person)
 Group Case Report (Telehealth)
 Group Raw Data - Live (In-Person)
 Group Raw Data - Live (Telehealth)
 Group Raw Data - Video (In-Person)
 Group Raw Data - Video (Telehealth)

Appendix I
AAMFT Code Of Ethics

[AAMFT Code of Ethics \(2015\)](#)

Appendix J

ACU Ethics Protocol

The ACU Online Marriage and Family Therapy Program is committed to demonstrating and maintaining the highest levels of professional competency and integrity. Students and faculty in the program are expected to know and abide by the regulatory and statutory laws that govern the practice of MFT as well as the current AAMFT *Code of Ethics* (2015).

The following paragraphs offer brief explanations regarding certain Standards of the *Code of Ethics* and their applicability to students' work in the program.

Standard I - Responsibility to clients

Students do not discriminate against clients or potential clients on the basis of race, age, ethnicity, socioeconomic status, disability, gender, health status, religion, national origin, sexual orientation, gender identity, or relationship status (1.1). In all clinical activities, students will strive to benefit the client system (1.9) and allow clients the right to make informed decisions about their treatment (1.8). It is imperative that students provide informed consent (1.2) to all clients and notify them of the student's intern status as well as gain written permission before recording sessions (1.12).

Standard II - Confidentiality

Maintaining client confidentiality is of paramount importance. In the informed consent documents, students will provide details about the limits of confidentiality and will review those limitations verbally (2.1). In order to release any client information, students will need written authorization (2.2); this is particularly important to remember when treating one member of a couple or family where secrets may be revealed. Students and licensed MFTs are not permitted to disclose any secrets without written authorization. Students should take appropriate measures to maintain confidentiality when charting, presenting cases in online supervision, and destroying videos after use (2.5; 2.7).

Standard III - Professional Competence and Integrity

Students should know the state statutes related to mandated reporting and other applicable laws and ethics related to the practice of marriage and family therapy (3.2). Students must know the procedures for making a mandated report within their state.

Standard VI - Technology-Assisted Professional Services

Before using technology for supervision, students must be familiar with the technology (6.1; 6.3) requirements and ensure the platform adheres to all ethical and legal standards.

Standard VII - Professional Evaluations

Students ensure they present a clear distinction between therapy and forensic evaluations (7.7) and avoid conflicts in providing those services for clients (7.6).

Standard IX - Advertising

Students ensure they represent their credentials accurately and in accordance with state statutes (9.1; 9.5).

This list is not exhaustive and if students have questions, they should consult with their MFT local program clinical supervisor or ACU faculty/program clinical supervisor.

Appendix K

FAQs

<p>Is the program accredited?</p>	<p>Yes, the program is accredited by the Commission on Accreditation for Marriage and Family Therapy Education (COAMFTE).</p>
<p>What is the difference between licensure requirements and what is required during the clinical internship?</p>	<p>Licensure requirements refer to the hours students will earn <i>post</i> master's degree that count toward their terminal license. These requirements vary across states. Clinical internship requirements satisfy what is necessary for students to earn their master's degree.</p>
<p>Can I be paid during my clinical internship?</p>	<p>It is highly uncommon for students to find an Internship site that allows them to be paid for their client contact. However, if the state statutes permit it, ACU policy does not prohibit students from being paid for clinical work.</p>
<p>Can I do my internship in a private practice rather than an agency?</p>	<p>First, students should ensure that their state allows interns to work in a private practice. Next, students should ensure the volume of the practice will allow them to earn enough client contact to graduate. Finally, students are prohibited from earning client contact hours in a ministerial setting in which they are already working.</p>
<p>Will I have to pay for local individual supervision?</p>	<p>Students may be able to secure a supervisor who will provide services for free and this is the most desirable option. Students who may have to pay, will likely pay the supervisor's regular rate. Students are advised to present a letter to the supervisor, requesting a reduction in the fee. This letter is found in the Internship Resources module in Canvas.</p>
<p>How long will it take to find a site and a local supervisor?</p>	<p>This process can take 6-9 months, depending on your location. Students are advised to</p>

	begin this process as soon as they begin the program.
Do I really have to earn at least 200 hours of couple and/or family clients?	Yes, in order to adhere to the standards of training in the field, the program requires that 40% of the 500 client contact hours (200) be provided to relational systems. In the path to earn 300 hours, 30% of the overall client contact must be relational (100 hours).
How do group therapy hours count?	Group therapy counts as individual client contact unless two or more members of the group are related by blood or affinity. Students are allowed to count 10% individual group hours or relational group hours toward their total.
Can I have more than one internship site at a time?	Yes, students may have more than one site at the same time. However, the second site (and supervisor, if necessary) must be approved before a student can begin to earn hours at that site.
Must I change sites during the internship experience?	No, unless there are extenuating circumstances.
Can I take more than one content course at a time?	The degree plan is designed such that students take one course at a time prior to beginning Internship. There may be occasions when the student is able to “double up” on coursework. To be eligible to take two non-Internship courses at the same time, students must meet criteria mentioned in an earlier section of this Handbook.
What is meant by the phrase <i>terminal license</i>?	Many states have a tiered licensure system with the lowest level being the entry point into the profession. In Texas, this is the Associate license (LMFT-A). After a certain period of time and after earning the designated number and type of client contact hours, Associates are eligible for full, or terminal, licensure. This refers to the highest level of licensure in a particular state. In

	Texas, this is the Licensed Marriage and Family Therapist (LMFT).
How do I talk with my clients about allowing me to record our sessions?	Students may wish to approach this conversation by citing the well-established literature about recording and watching sessions in supervision as an integral part of family therapy training (Liddle & Halpin, 1978). Students may also reiterate the standards of confidentiality and reassure clients their information will be treated with the utmost care in keeping with the <i>Code of Ethics</i> .
How long will I have access to my ACU email account after I graduate?	Students will have access to their ACU email account for one year after graduation. The University account retention policy can be found here: https://support.acu.edu/TDCClient/1963/Portal/KB/ArticleDet?ID=138391
Do I have access to my Canvas courses after the course ends?	Students have view-only access after the course closes at the end of the term.
Can I engage in pastoral counseling at my church?	Students cannot engage in pastoral counseling while in the program.
Am I permitted to see clients at my site after I complete my Internship requirements?	Students cannot engage in clinical practice once they have completed the program's Internship requirements.
Can I see clients if my site supervisor is not physically present during my session?	Students shall not see clients unless the site supervisor is physically present or has designated another licensed mental health clinician to serve as the site supervisor in their absence.

Appendix L

MFT Local Program Clinical Supervisor Evaluation

The evaluation can be found here: <https://forms.gle/GnRUf8KrkXFEBpyD9>

All evaluations must be submitted through Google forms.

Appendix M

Evaluation Of Clinical Internship

The evaluation can be found here: <https://forms.gle/NeCDUrmhgiJtJp6B6>

All evaluations must be submitted through Google forms.

Appendix N

Internship Search Process

Students begin the program with MFTO 601 Pre-Internship and proceed through the next five courses in preparation to begin Internship. From the beginning of the program until graduation, the student has access to the Internship module in Canvas (Internship information including Online MFT Student Handbook, forms, videos, tips, FAQ's, etc.).

Internship is scheduled to begin after the student successfully completes the first six courses. However, the student should begin the internship site and supervisor search process during the first course in the program. It is common for the process to take 6-9 months.

Begin the search process by visiting www.aamft.org and searching for Approved Supervisors in your area. Search by zip code within a specified mile radius, and expand the range to increase possible options. Search for Approved Supervisors who are affiliated with an agency, or who are involved in a group practice because the optimal internship site/supervisor combination is one with an Approved Supervisor. At the same time, search via the Internet for local/area social services agencies (outpatient mental health services that include a relational focus). Review therapy staff member credentials, looking for those licensed as MFTs. Examine the services offered, looking for child/adolescent, marital/couple, and family therapy specifically.

The optimal internship setting is one where the student can accrue the necessary number of clinical hours (and specifically relational hours) and is supervised by an AAMFT Approved Supervisor (or an AAMFT Approved Supervisor Candidate) as part of their work at the site (the student does not pay for supervision). The reality is that this optimal situation is less likely to occur because of the overall relative availability of Approved Supervisors (and especially those who are working in an agency setting). Students may have to pay for individual supervision.

Contact a potential site by phone, and request an in-person appointment with the person responsible for interns (it is possible that the site has never had an intern but is interested in you joining them). Ask if you can send materials via email in advance of the meeting, and if acceptable, forward a brief cover letter expressing your interest, a copy of your professional resume, and a copy of "Information for Site Supervisors" (Part III of the Online MFT Student Handbook). (Note: Once a site and supervisor are secured, the student should provide a complete copy of the Online MFT Student Handbook to their local supervisor).

In the meeting with a potential site and supervisor, explain your interest in wanting to complete your internship at the site, offer a brief overview of the Internship requirements, and briefly

describe your potential to contribute as a MFT intern. (Note: If you were not able to send materials via email in advance, bring hard copies to the in-person meeting). Be prepared by having a beginning knowledge about the site and supervisor (review websites), and be interested in learning more about the site and supervisor. Sites who accept multiple students/interns may have a rotation of slots already filled for the current semester or term. It is important to be clear about your timeline.

Appendix O

Program Costs

Students will select one path to earn either 300 or 500 client contact hours in their chosen degree plan. The costs for each path are listed below and are current as of Spring 2024. The overall program cost is subject to change. The degree plan is designed so that students begin Internship while also continuing with their coursework. Students who opt to complete the Internship courses after completing all of their other courses should consult with Student Financial Services to ensure they are informed about the impact to financial aid.

Students should understand these costs do not include membership in the AAMFT or other costs associated with individual supervision while in Internship. Any questions about financial aid should be directed to Student Financial Services.

- 300-client contact hours
 - 60 total credit hours
 - 51 content course hours (@ \$799/hr)
 - 9 internship hours (@ \$470/hr)
 - Total estimated cost of program: \$40,749 (course tuition) + \$4230 (Internship hours) + \$3,400 (resource fees) = \$48,379
- 500-client contact hours
 - 60 total credit hours
 - 48 content course hours (@ \$799/hr)
 - 12 internship hours (@ \$470/hr)
 - Total estimated cost of program: \$38,352 (course tuition) + \$5,640 (Internship hours) + \$3,200 (resource fees) = \$47,192

Appendix P

Student and Graduate Achievement Goals & Outcomes Assessment Report (OAR)

Achievement and Goals

Annually, in the Spring 1 term, the core faculty review the following metrics of Student and Graduate Achievement.

The Program defines *Student Achievement* as:

- 1) 70% of students in each cohort will graduate in the advertised length of time;
- 2) 100% of students will maintain membership in the AAMFT during the entire length of the program; and,
- 3) 70% of students will earn minimum scores of 3 on the Capstone Paper and Presentation.

The Program defines *Graduate Achievement* as:

- 1) 70% overall program graduation rate among those who begin the Foundational Practice Component;
- 2) a 70% pass rate among respondents on the AMFTRB National Exam;
- 3) a minimum of 70% of respondents will be working as marriage and family therapists; and,
- 4) a minimum of 70% of respondents will be licensed in their state or province as MFTs.

After a review of the aggregated data, the faculty determine what, if any, changes to implement to the program.

OAR

The institutional accreditor, SACSCOC, requires that all educational programs have student learning outcomes and that we use the results to improve our programs. Their standard says, “The institution identifies expected outcomes, assesses the extent to which it achieves these outcomes, and provides evidence of seeking improvement based on analysis of the results.” This is congruent with COAMFTE’s expectation that programs have an outcome-based educational framework. The program’s assessment schedule is found [here](#).